

JAURE®

Crowned tooth gear couplings

TYPE MT



A Regal Brand

REGAL

JAURE®.

Experience, innovation
and close cooperation
with leading international
companies.

JAURE® is a leading supplier of couplings and power transmission solutions. Experience, manufacturing program, innovation and close cooperation with leading International companies in the business enables JAURE® to provide customized solutions to our customers.

For over 50 years, JAURE® has developed couplings for the most demanding applications in marine, wind energy, steel, railway and paper industries among others.

Our manufacturing program covers a complete range without boundaries in power and speed, and we continue developing new products for future challenges.

JAURE® is part of Regal Power Transmission Solutions, a division of Regal Beloit Corporation. Regal Power Transmission Solutions is comprised of 8 brands: Browning, Jaure, Kop-Flex, McGill, Morse, Rollway, SealMaster and System Plast. Particularly the integration of Kop-Flex and Jaure coupling businesses has strengthened Jaure's presence worldwide and has added application expertise to provide answers, products and service to our customers on a global basis.

MT Gear Coupling Introduction

JAURE MT Crowned Tooth Gear Couplings

Jaure was founded in Spain in 1958 as a machining workshop in one of the most industrialized areas with strong steel and iron tradition. Jaure's flexible coupling manufacturing activity as it is known nowadays started back in 1970 with the production of the first gear coupling MS model.

Along the last 50 years, the design of Jaure gear coupling has been continuously improved from, MS serie, to MN, then HA until the nowadays known Jaure MT gear coupling.

Below equivalences of the various models of Jaure gear coupling:

Industrial MT	Marine MT	HA	MS	MN
52	42	10	5	5
62	55	15	10	10
78	70	20	20	20
98	90	25	35	35
112	100	30	60	60
132	125	35	105	105
156	145	40	150	150
174	165	45	210	210
190	185	50	325	325
210	205	55	430	430
233	230	60	600	600
275	260	70	800	800



Thousands of Jaure gear couplings are operating today in the toughest applications such as steel mills, pulp and paper, mining, cement, marine drives, wind turbines, etc.

MT gear couplings are the most compact coupling solution for critical applications that demand high torque transmission.



Main advantages of MT gear couplings

- Jaure® couplings offer maximum torque capacity. This is due to the optimum pitch diameter of the gears, providing reliability.
- High permissible hub bore allows more favorable size selection of the coupling for a certain shaft diameter. This offers an important economic saving.
- High permissible additional loads for starting and short-circuit peak torque.
- Highest gear accuracy and quality thanks to the production improvements obtained with new CNC gear cutting machines and automatic change systems.
- The design, manufacture and sale of all Jaure's gear couplings and drive components are integrated into Jaure's Quality System. This is according to ISO 9001 and certified by DET NORSKE VERITAS (DNV).
- The Jaure MT standard range meets the AGMA standard, meaning that the MT coupling sleeves and drilled holes will fit any AGMA coupling halves. This ensures the interchangeability by coupling halves.

Custom made couplings

Special designs according to customer needs often come from close co-operation with our R&D and Engineering departments. Special solutions are normally based on the use of special seals and alloyed steels subjected to surface hardening treatments, such as:

- Nitriding
- Case carburizing
- Induction hardening

In addition to our R&D department validation procedures, MT gear couplings are analysed by specific software based on FEA. JAURE also collaborates with Technological Centres, which combined with our worldwide network of technical experts, enables us to provide innovative engineered solutions to our customers.











Marine Type Approval & Manufacturing Survey Arrangement



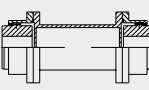
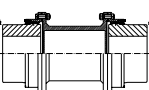
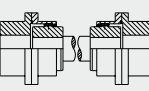

The Jaure MT gear couplings can be also delivered on demand with the 3.2 certificate of any Marine Classification Society.

Jaure is besides awarded with the Manufacturing Survey Arrangement – MSA from DNV. The MSA certificate is our commitment to continuously improve the service and response time to our customers and remain competitive in the market place.

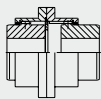
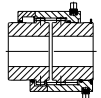
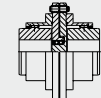
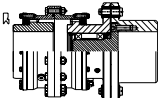

Summary of Contents

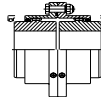
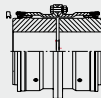
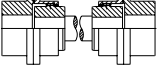
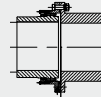
JAURE MT GEAR COUPLING			Page
Description			8
Coupling Selection			10
Balancing			12
Critical Speed			14
Service Factors			15
Coupling design	Type	Description	Page
INDUSTRIAL DESIGNS			
	MT / MT-HD	Basic Design Standard / Heavy Duty	17
	MTT / MTT-HD	With Covers Standard / Heavy Duty	18
	MTS	With Single Sleeve	19
	MTG / MTG-HD	Basic Design Standard / Heavy Duty	20
	MTV	Vertical Installation	21
	MTX / MTX-HD	With Spacer Standard / Heavy Duty	22
	MTGX / MTGX-HD	With Spacer Standard / Heavy Duty	23
	MTD / MTD-HD	With Floating Shaft Standard / Heavy Duty	24
	MTGD / MTGD-HD	With Intermediate Floating Shaft Standard / Heavy Duty	25
	MTFE	With Intermediate Brake Disc and Axially Limited	26
	MTFS	With Brake Disc	27
	MTF	With Intermediate Brake Drum	28
	MTFE	With Side Brake Drum	29

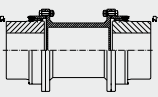
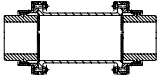
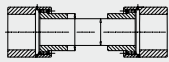
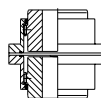
	MTCO	With Axial Stroke	30
	MTES	Disengaging	31
	MTB	With Shear Pins	32
	MTNBR	With Shear Pins	33
	PLMT	Rigid	34
MARINE DESIGNS			
	MT / MT-HD	Basic Design Standard / Heavy Duty	36
	MTG / MTG-HD	Basic Design Standard / Heavy Duty	37
	MTD / MTD-HD	With Floating Shaft Standard / Heavy Duty	38
	MTGD / MTGD-HD	With Intermediate Floating Shaft Standard / Heavy Duty	39
	MTX / MTX-HD	With Spacer Standard / Heavy Duty	40
	MTGX / MTGX-HD	With Spacer Standard / Heavy Duty	41
	MTX-LI	Oil Lubricated With Spacer	42
	MTD-LE	Lubricated With Floating Shaft	43
	MTV	Vertical Installation	44
OTHER INFORMATION			Page
Shaft Connection Types			46
Shaft / Bore Fits			47
Axial Forces Calculation			47
MT Designs			48
MT References			52

MT Gear Coupling Description

The MT gear coupling is a steel double-joint coupling. Main function is to transmit torque and at the same time accommodate the misalignment between two shafts.

The MT coupling is torsionally stiff and formed by two crowned hubs which engage two flanged sleeves with internal straight parallel teeth (see coupling parts at Fig n°1).

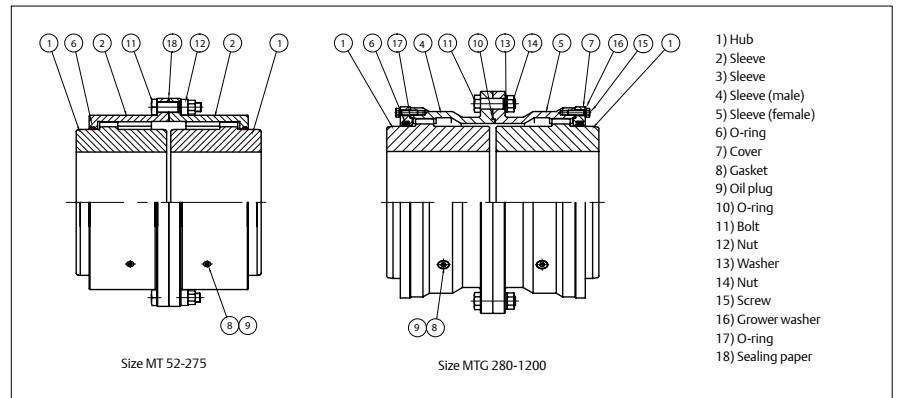

Fig n°1. Coupling components

As a result of the teeth curvature, if shafts misalignment occurs, the crowned teeth hubs can oscillate in the flanged sleeve (see Fig n°2).

It is impossible to have corner pressure even at maximum misalignment. The combined tip and flank centering and fully machined coupling ensure smooth operation.

In case of high rotation speed (circumferential speeds exceeding 40 m/s or sensitive supports to unbalance) dynamic balancing is required.

The teeth are machined with precision gear machines in order to assure uniform contact on all the teeth.

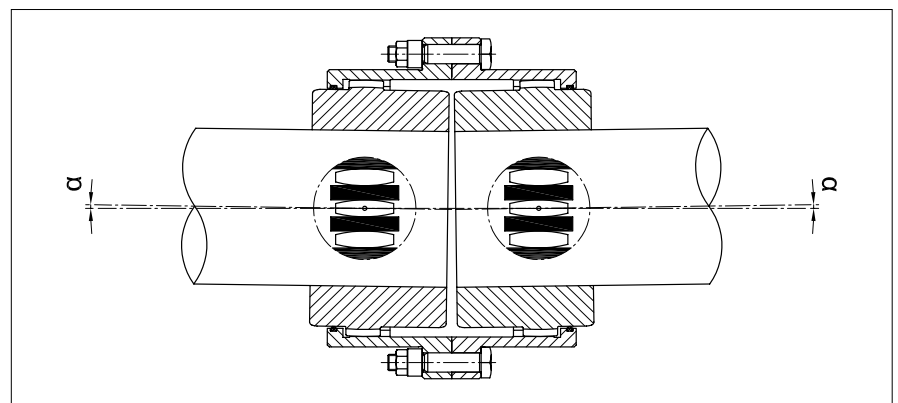

Fig n°2. Detail of the crowned teeth with angular misalignment

Coupling size for certain drive depends not only on the drive unit power and speed, but also on the misalignment and the type of machines to be coupled.

Three types of misalignment can be effectively accommodated by the MT gear coupling (see Fig. n°3):

- Axial: Shafts are aligned but shaft ends are apart from each other.
- Parallel Offset: Axes of connected shafts are parallel, but not in the same straight line.
- Angular: Axes of shafts intersect at center point of coupling, but not in the same straight line.

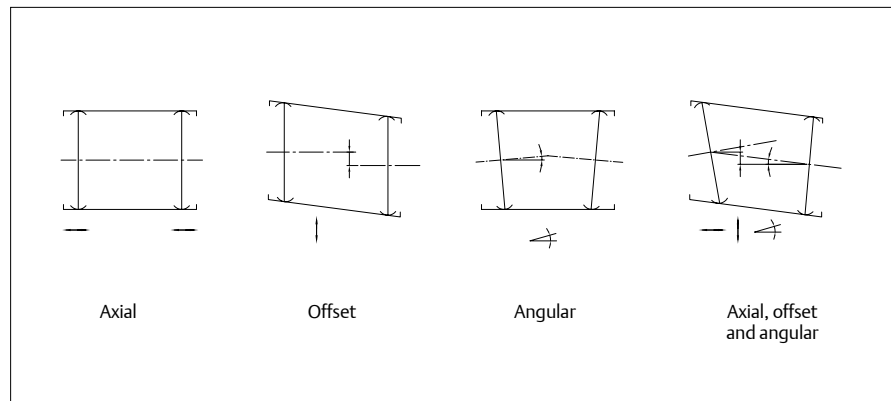

Fig n°3. Shaft misalignment

Proper maintenance of gear couplings is key to avoid early wear of the gear teeth and extend the coupling's life. It is necessary to strictly follow the installation and maintenance instructions.

The MT gear coupling must be filled with grease periodically. Therefore, the lubrication is forced into the teeth by centrifugal force. Seals are provided in the sleeves/covers to prevent any grease leakage. They can be used at -30°C to 70°C temperature range. For other temperature, please contact Jaure.

The gear couplings are made in C45/55 material as a standard. If a more compact coupling or higher power ratio is required, **Jaure Heavy Duty Type (HD)** in alloy steel is available in our program.

In addition other special designs with heat treatments such as induction hardening, gas nitriding, case hardening, etc can be delivered on demand. Please contact our engineering or sales departments.

For more detailed information refer to Jaure instruction manual.

Coupling Selection

For MT standard design selection, the following data is required:

- P_N , Installed or absorbed power (Kw)
- n , operating speed (rpm)
- L , d shaft lengths and diameters (mm)
- DBSE distance between shaft ends (mm)
- Service requirements (K service factor from page 15)
- Dynamic misalignment (F_a misalignment factor from Fig n°4)
- Additional geometrical or atmospheric restrictions

Torque Capacity varies with speed and dynamic misalignment. A coefficient (f_a = Coefficient factor from dynamic misalignment and speed) is required over 0,1 degrees of misalignment and is affected in the following trend:

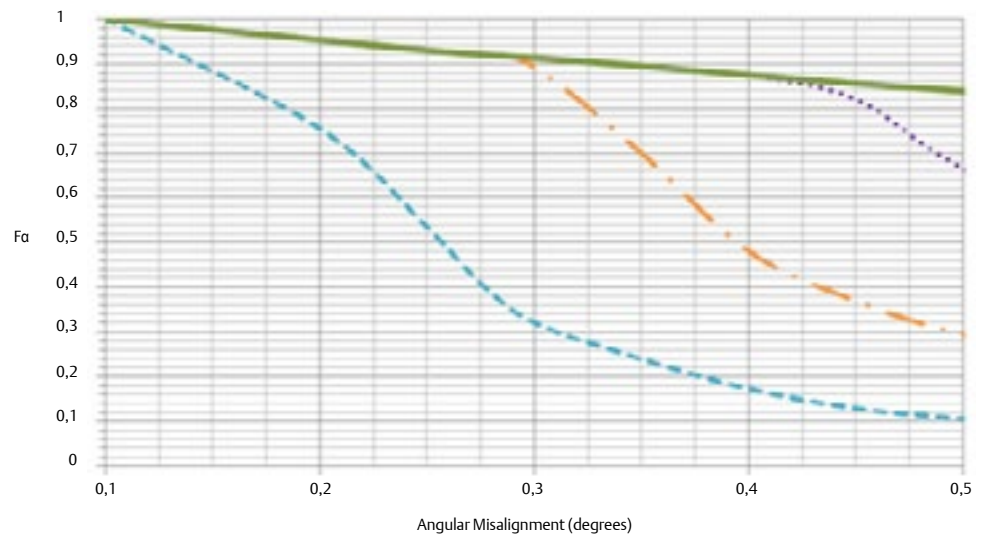

Fig. n° 4 Trend of Coefficient with Dynamic Misalignment and Speed

- $n = n_{max}$
- - - $n = 0.6 \cdot n_{max}$
- ... $n = 0.4 \cdot n_{max}$
- $n = 0.15 \cdot n_{max}$

Above graph shows one gear mesh misalignment.

Values shown in the graph are indicative. For accurate calculation or higher angular misalignment please contact Jaure.

Selection procedure

1) Calculate nominal torque T_N (Nm) as follows:

$$T = 9550 \frac{P_N \cdot K}{n \cdot F\alpha}$$

P_N = Max. actual power in (Kw)

n = Coupling speed in (rpm.)

K = Service factor

$F\alpha$ = Misalignment factor

Select coupling size from catalogue with nominal torque capacity same or higher than obtained. Check if the peak torque of the application is below the coupling max. torque (T_{Pmax}).

2) Check in the catalogue maximum bore capacity for selected coupling. Should shafts be larger than the maximum admissible bore, select next bigger necessary size diameter.

3) Check shaft/hub connection is able to transmit the torque. If necessary, extend the hub length.

4) Speed given in catalogue is maximum value for unbalanced couplings. For higher operational speed the coupling must be dynamically balanced and other materials than carbon steels might be used. Please contact Jaure engineering for support.

5) Selection Service Factors (K): Recommended service factors are given on page 15.

The service factor can vary for each application and depending among other on:

- Type of driving and driven machine
- Reversing / Non-reversing load
- Peak torques

Example:

Find a coupling to connect a gearbox with the drum of a conveyor.

Motor power $P_N = 400$ Kw.

Peak torque: 7200 Nm

Drum speed $n = 1.000$ r.p.m.

Gearbox shaft $d_1 = 80$ mm.

Drum side shaft $d_2 = 100$ mm.

Dynamic misalignment $< 0,1$ degrees. $F\alpha = 1$

Service Factor for Conveyor Heavy Duty Not Uniformly Fed Assembly in page 15, $K = 1.25$

Solution:

$$T = 9550 \frac{400 \cdot 1,25}{1000 \cdot 1} = 4775 \text{ Nm}$$

Nominal torque needs to be checked as a first step. From MT basic design, we would select MT-78. Secondly, we need to check maximum shaft capacity for selected size. This would lead to the selection of MT-112, as the drum shaft diameter is 100 mm.

Check that Peak Torque of application 7200 Nm is below selected coupling limit (28200 in this case).

With this selection, resulting Service factor can be calculated:
Since

$$T_{\text{application}} = 9550 \frac{P_N}{n} = 9550 \frac{400}{1000} = 3820 \text{ Nm}$$

Resulting Service Factor can be calculated as

$$K = \frac{14000}{3820} = 3,67$$

Balancing

Coupling Balance requirements and limits are mainly dependent upon the characteristics of the application. For this reason balancing charts should be used as a guide only to assist in determining whether balancing is required or not.

Balancing chart is shown for average applications. For sensitive or critical application, contact Jaure for coupling balance requirement.

Balance Chart for non spacer type gear couplings

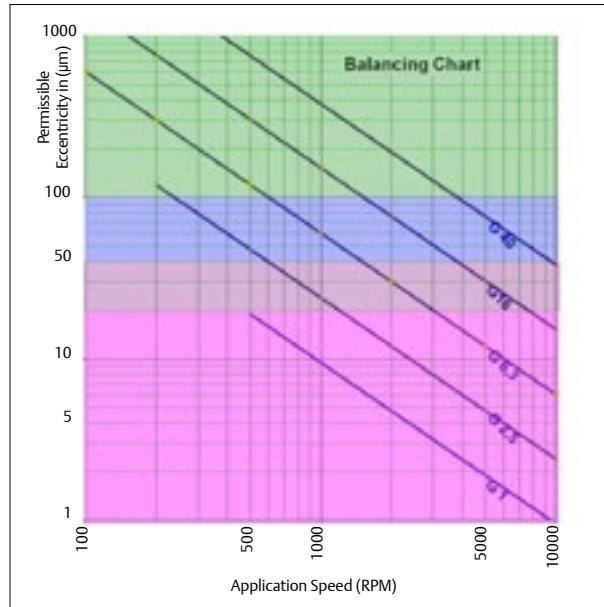

Fig. n° 5

Balance Chart for intermediate shaft couplings up to 1000mm of DBSE (For higher DBSE please refer to Jaure)

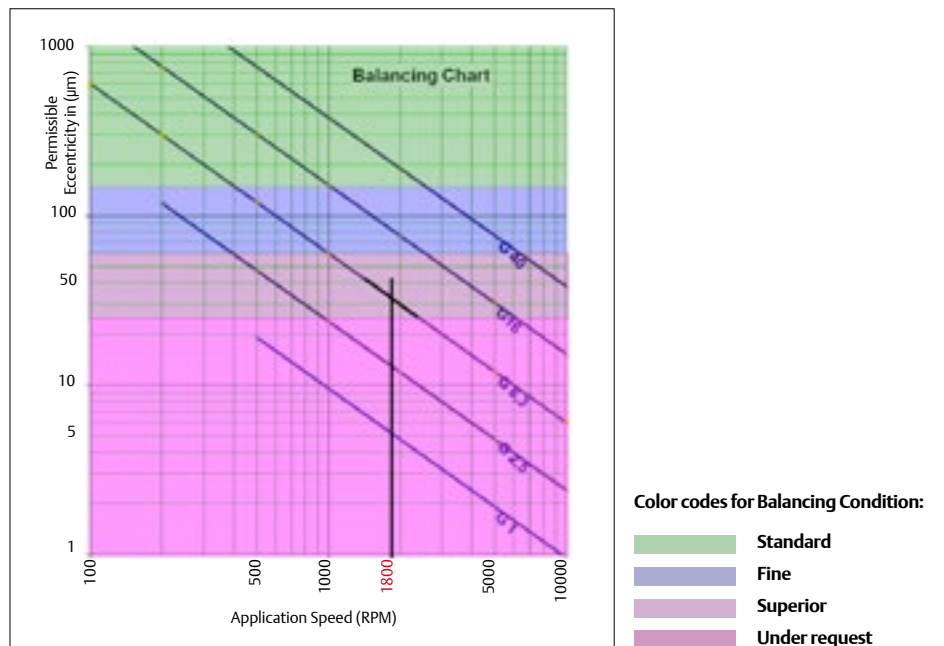

Fig. n° 6

Balancing

Minimum applications data required for chart interpretation:

1. ISO balancing Grade for the coupling. (G)
2. Application Speed (n)

This information allows to calculate the permissible eccentricity (e permissible) for the coupling.

$$e \text{ permissible} = 9550.G/n$$

Where,

e permissible = Permissible eccentricity of center of gravity in μm .

e coupling = Actual eccentricity of center of gravity of coupling in μm .

G = Balance Grade in mm/s

n = Application speed in rpm.

In order to satisfy the application requirement, $e \text{ coupling} \leq e \text{ permissible}$.

Balancing Practices

Jaure couplings are dynamically balanced in component level or in sub-assembly.

In case of sub-assembly balancing level, major components are match-marked to ensure the proper reassembly of the coupling.

Hubs are component balanced at finished bore without keyways unless mentioned in the order.

On special request from customer, assembly balancing of gear coupling including gear hubs can be performed.

Balancing reports will be available for customer under request.

Example:

Coupling Type – Spacer type Gear Coupling.

DBSE – 600 mm

Required Balance Quality – 6.3

Application Speed – 1800 rpm

As per the chart, we require to perform the superior balancing for the spacer coupling to achieve the 6.3 balancing grade as per ISO-1940-1.

Alternatively:

$$\begin{aligned} e \text{ permissible} &= 9550.G/n \\ &= 9550.(6.3)/1800 \\ &= 33,4 \mu\text{m} \end{aligned}$$

From the chart (Y-axis) for 33,4 μm permissible eccentricity, coupling requires Superior balancing.

Critical Speed

Critical speed needs to be checked for intermediate shaft couplings.
 Note: For an approximate calculation the spacer/shaft length can be used instead of the distance between gear mesh.

Fig n°7
 Critical speed for intermediate shaft couplings type MTX and MTXCO.

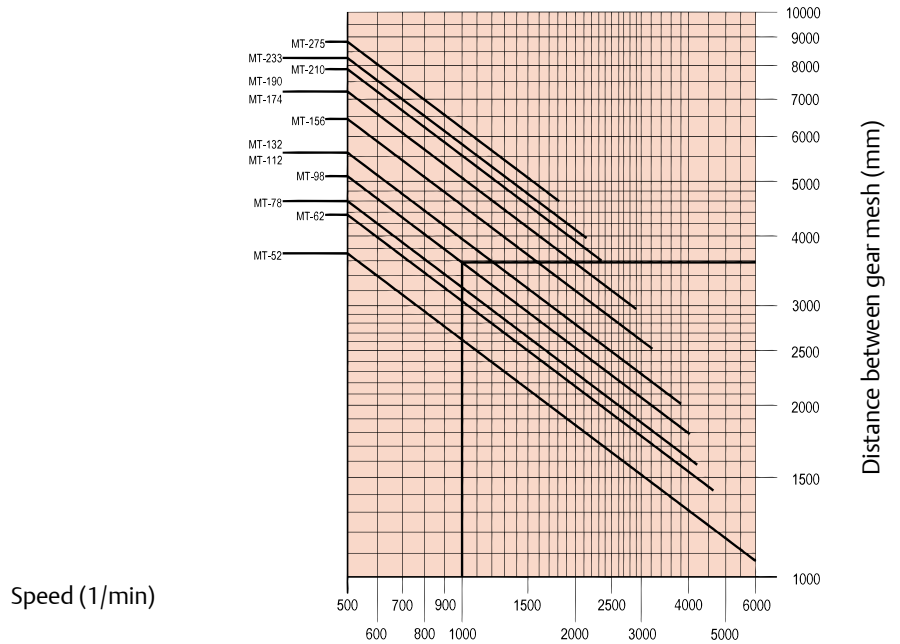

Ex.: MTX-98 with a spacer of 3575 mm can rotate at a speed maximum 1000 rpm

Fig n°8
 Critical speed for intermediate shaft couplings type MTD.

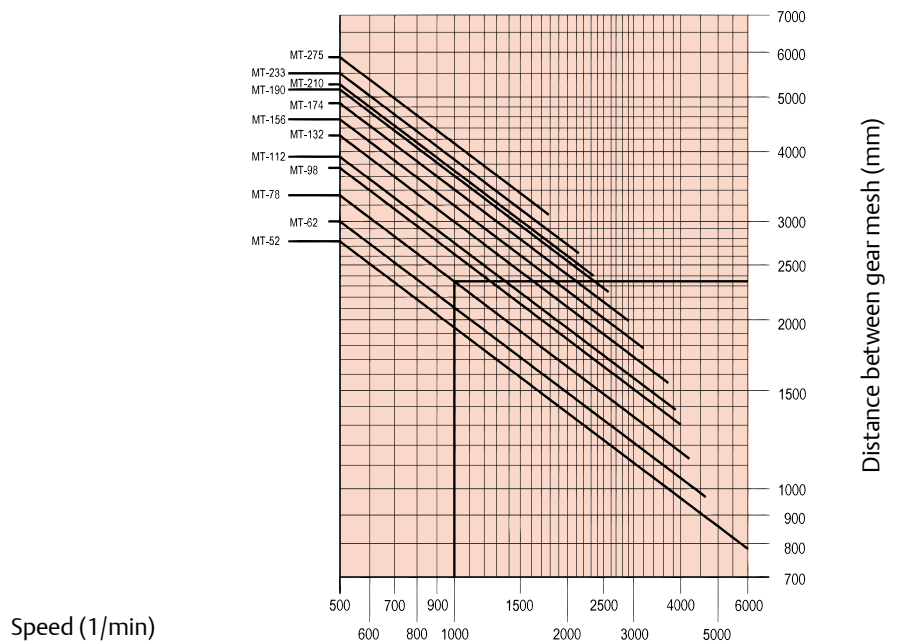

Ex.: MTD-78 with an intermediate shaft of 2350 mm can rotate at a speed maximum 1000rpm

Recommended Service Factors (K)

Values listed are intended only as a general guide, and are typical of usual service requirements. For systems which frequently utilize the peak torque capability of the power source, verify that the magnitude of this peak torque does not exceed the 1.0 Service Factor Rating of the coupling selected. Applications which involve extreme repetitive shock or high-energy load absorption characteristics should be referred -with full particulars- to JAURE.

Values contained in the table are to be applied to smooth power sources such as electric motors and steam turbines. For drives involving internal combustion engines of four or five cylinders, add 1.0 to the values listed; for six or more cylinders, add 0.5 to the values listed. For systems utilizing AC or DC Mill Motors as the prime mover, refer to Note (1).

CAUTION: All people moving applications must be referred to engineering.

JAURE®

Application:	Typical Service Factor
AGITATORS	
Pure Liquids	1.0
Liquids & Solids	1.25
Liquids - Variable Density	1.25
BLOWERS	
Centrifugal	1.0
Lobe	1.5
Vane	1.25
BRIQUETTE MACHINES	2.0
CAR PULLERS - Intermittent Duty	1.5
COMPRESSORS	
Centrifugal	1.0
Centriaxial	1.25
Lobe	1.5
Reciprocating-Multi-Cylinder	2.0
CONVEYORS-LIGHT DUTY UNIFORMLY FED	
Apron, Bucked, Chain, Flight, Screw	1.25
Assembly, Belt	1.0
Oven	1.5
CONVEYORS-HEAVY DUTY NOT UNIFORMLY FED	
Apron, Bucket, Chain, Flight, Over	1.5
Assembly, Belt	1.25
Reciprocating, Shaker	2.5
CRANES AND HOISTS (NOTE 1 and 2)	
Main hoists, Reversing	2.5
Skip Hoists, Trolley & Bridge Drives	2.0
Slope	2.0
CRUSHERS	
Ore, Stone	3.0
DREDGES	
Cable Reels	1.75
Conveyors	1.5
Cutter Head Jig Drives	2.5
Maneuvering Winches	1.75
Pumps	1.75
Screen Drives	1.75
Stackers	1.75
Utility Winches	1.5
ELEVATORS (NOTE 2)	
Bucket	1.75
Centrifugal & Gravity Discharge	1.5
Escalators	1.5
Freight	2.5
FANS	
Centrifugal	1.0
Cooling Towers	1.5
Forced Draft	1.5
Induced Draft without Damper Control	2.0
FEEDERS	
Apron, Belt, Disc, Screw	1.25
Reciprocating	2.5

Application:	Typical Service Factor
GENERATORS (Not Welding)	1.0
HAMMER MILLS	2.0
LAUNDRY WASHERS	
Reversing	2.0
LAUNDRY TUMBLERS	2.0
LINE SHAFT	1.5
LUMBER INDUSTRY	
Barkers-Drum Type	2.0
Edger Feed	2.0
Live Rolls	2.0
Log Haul-Incline	2.0
Log Haul-Well type	2.0
Off Bearing Rolls	2.0
Planer Feed Chains	1.75
Planer Floor Chains	1.75
Planer Tilting Hoist	1.75
Slab Conveyor	1.5
Sorting Table	1.5
Trimmer Feed	1.75
MARINE PROPULSION	
Main Drives	2.25-2.5
MACHINE TOOLS	
Bending Roll	2.0
Plate Planer	1.5
Punch Press - Gear Driven	2.0
Tapping Machines	2.5
Other Machine Tools	
Main Drives	1.5
Auxiliary Drives	1.25
METAL MILLS	
Draw Bench - Carriage	2.0
Draw Bench - Main Drive	2.0
Forming Machines	2.0
Slitters	1.5
Table Conveyors	
Non-Reversing	2.25
Reversing	2.5
Wire Drawing & Flattening Machine	2.0
Wire Winding Machine	1.75
METAL ROLLING MILLS (NOTE1)	
Blooming Mills	*
Coilers, hot mill	2.0
Coilers cold mill	1.25
Cold Mills	2.0
Cooling Beds	1.75
Door Openers	2.0
Draw Benches	2.0
Edger Drives	1.75
Feed Rolls, Reversing Mills	3.5
Furnace Pushers	2.5
Hot Mills	3.0
Ingot Cars	2.5
Kick-outs	2.5
Manipulators	3.0
Merchant Mills	3.0
Piercers	3.0
Pushers Rams	2.5
Reel Drives	1.75
Reel Drums	2.0
Reelers	3.0
Rod and Bar Mills	1.5
Roughing Mill Delivery Table	3.0
Runout Tables	
Reversing	3.0
Non-Reversing	2.0
Saws, hot & cold	2.5
Screwdown Drives	3.0
Skelp Mills	3.0
Slitters	3.0
Slabbing Mills	3.0
Soaking Pit Cover Drives	3.0
Straighteners	2.5
Tables, transfer & runout	2.0
Thrust Block	3.0
Traction Drive	3.0
Tube Conveyor Rolls	2.5
Unscramblers	2.5
Wire Drawing	1.5
MILLS, ROTARY TYPE	
Ball	2.25
Dryers & Coolers	2.0
Hammer	1.75
Kilns	2.0

Application:	Typical Service Factor
Pebble & Rod	2.0
Pug	1.75
Tumbling Barrels	2.0
MIXERS	
Concrete Mixers	1.75
Drum Type	1.5
OIL INDUSTRY	
Chillers	1.25
Paraffin Filter Press	1.75
PAPER MILLS	
Barker Auxiliaries, Hydraulic	2.0
Barker, Mechanical	2.0
Barking Drum Spur Gear Only	2.25
Beater & Pulper	1.75
Bleacher	1.0
Calenders	2.0
Chippers	2.5
Coaters	1.0
Converting Machines except Cutters, Platers	1.5
Couch Roll	1.75
Cutters, Platers	2.0
Cylinders	1.75
Disc Refiners	1.75
Dryers	1.75
Felt Stretcher	1.25
Felt Whipper	2.0
Jordans	1.75
Line Shaft	1.5
Log Haul	2.0
Pulp Grinder	1.75
Press Roll	2.0
Reel	1.5
Stock Chests	1.5
Suction Roll	1.75
Washers & Thickeners	1.5
Winders	1.5
PRINTING PRESSES	1.5
PULLERS - Barge Haul	2.0
PUMPS	
Centrifugal	1.0
Boiler Feed	1.5
Reciprocating	
Single Acting	
1 or 2 Cylinders	2.25
3 or more Cylinders	1.75
Doble Acting	2.0
Rotary, Gear, Lobe, Vane	1.5
RUBBER INDUSTRY	
Mixer - Banbury	2.5
Rubber Calendar	2.0
Rubber Mill (2 or more)	2.25
Sheeter	2.0
Tire Building Machines	2.5
Tire & Tube Press Openers	1.0
Tubers & Strainers	2.0
SCREENS	
Air Washing	1.0
Grizzly	2.0
Rotary - Stone or Gravel	1.5
Traveling Water Intake	1.25
Vibrating	2.5
SEWAGE DISPOSAL EQUIPMENT	
Bar Screens	1.25
Chemical Feeders	1.25
Collectors, Circuline or Straightline	1.25
Dewatering Screens	1.25
Grit Collectors	1.25
Scum Breakers	1.25
Slow or Rapid Mixers	1.25
Sludge Collectors	1.25
Thickeners	1.25
Vacuum Filters	1.25
STEERING GEAR	1.0
STOKERS	1.0
WINCH	1.5
WINDLASS	1.75

*Refer to JAURE.

Notes:

(1) Maximum Torque at the coupling must not exceed Rated Torque of the coupling.

(2) Check local and industrial safety codes.

Industrial designs

Jaure gear couplings are used in a variety of demanding applications since years. Paper mill, cranes, pumps, conveyors and any process in a steel, aluminum or cooper mill are just some of the examples where Jaure gear couplings are performing successfully.

Numerous designs and coupling sizes are available. The custom-made gear coupling offering is developed in close collaboration with the customer.

MT/MT-HD Basic Design

Industrial

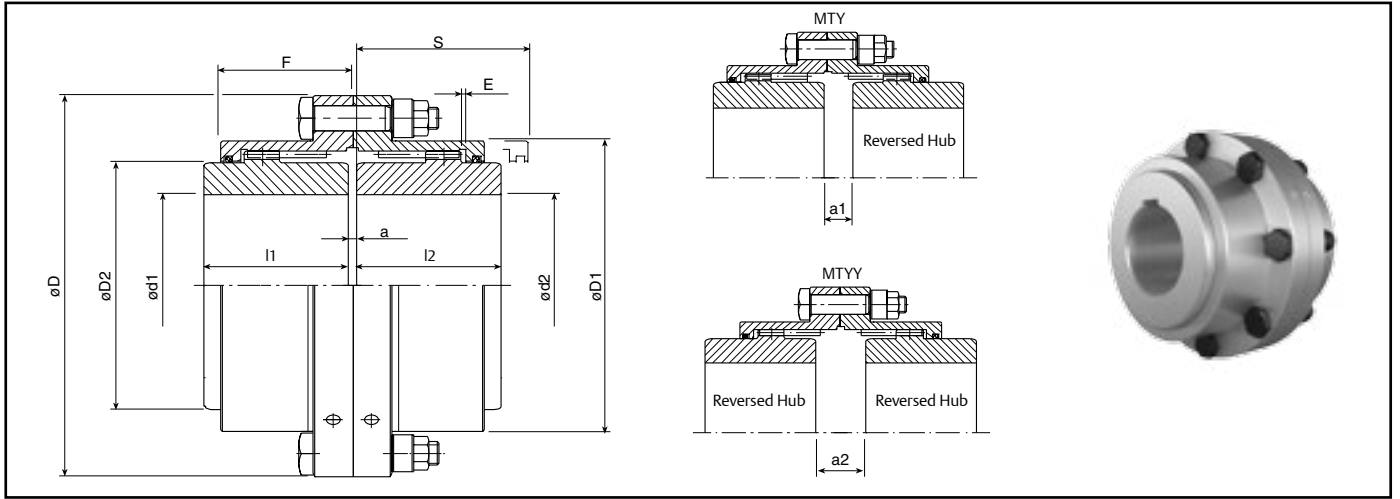

Designation example:

MT-132	Basic design
MT-Y-132	One reversed hub
MT-YY-132	Two reversed hubs

SIZE	MT		MT-HD		n MAX (8)	GENERAL DIMENSIONS											WEIGHT Max. (5)	WEIGHT Min. (6)	MOMENT OF INERTIA (5)	GREASE QTY. (7)				
	TN NOMINAL (1)	TP MAX (1)	TN NOMINAL (1)	TP MAX (1)		D	D1	D2	d1-d2 (Min-Max) (2)(3)	l1-l2	a	a1	a2	E	F	S(4)					kg	kg	J (kgm ²)	kg
MT					rpm																			
MT-HD	Nm	Nm	Nm	Nm																				
52	1.780	3.600	2.937	5.940	8.600	111	82,5	69	14-52	43	3	5	7	1,5	39	57	4	3	0,005	0,03				
62	2.790	5.520	4.604	9.108	7.000	141	104,5	85	17-62	50	3	8	13	1,5	46	64	8	6	0,016	0,06				
78	5.600	11.100	9.240	18.315	5.800	171	127,5	107	20-78	62	3	14	25	1,5	61	76	14	10	0,040	0,09				
98	8.500	17.400	14.025	28.710	4.700	210	156	133	26-98	76	5	12	19	2,5	69,5	92	26	18	0,11	0,14				
112	14.000	28.200	23.100	46.530	4.200	234	181,5	152	30-112	90	5	24	43	2,5	84,5	108	39	26	0,20	0,29				
132	23.000	45.600	37.950	75.240	3.600	274	210,5	178	35-132	105	6	27	48	3	96	125	58	42	0,45	0,42				
156	35.100	69.600	57.915	114.840	3.200	312	248,5	209	70-156	120	6	32	58	3	109	140	91	61	0,88	0,60				
174	44.400	88.000	73.260	145.200	2.900	337	274	234	85-174	135	8	37	66	4	123	162	115	77	1,33	1,04				
190	68.500	139.600	113.025	230.340	2.600	380	308,5	254	95-190	150	8	50	92	4	142,5	180	165	115	2,48	1,73				
210	84.600	167.600	139.590	276.540	2.400	405	334	279	110-210	175	8	52	96	4	154,5	205	211	142	3,59	2,48				
233	151.000	304.000	249.150	501.600	2.200	444	365,5	305	120-233	190	8	58	108	4	166,5	218	260	167	5,00	3,46				
275	205.500	407.000	339.075	671.550	2.000	506	424	355	130-275	220	10	72	134	5	193,5	252	411	252	10,39	5,31				

From size 174 (included) the coupling is supplied by default with puller holes. If required, puller holes can also be made for smaller sizes.

Setscrews can be included upon request.
Adapted hub length available upon request.

ATEX certifications are available. Please, contact JAURE to define the zone and category.



(1) The torque of the coupling does not include the connection transmission capacity.

(2) Minimum dimensions refer to already machined bore.

For A00 rough bore dimensions contact JAURE.

(3) Max. allowable bore for couplings with DIN 6885/1 keys.

For other types of keys or connections please contact JAURE.

(4) Clearance to align coupling hubs and replacement of sealing rings.

(5) Weight and moment of inertia are given for minimum bore.

(6) Weight is given for maximum bore.

(7) The amount of grease indicated in the catalogue is for guidance only.

For exact amount please refer to coupling instructions.

(8) n MAX speed for balanced couplings. For higher speeds contact JAURE.

Technical modifications reserved

MTT/MTT-HD With Covers

Industrial

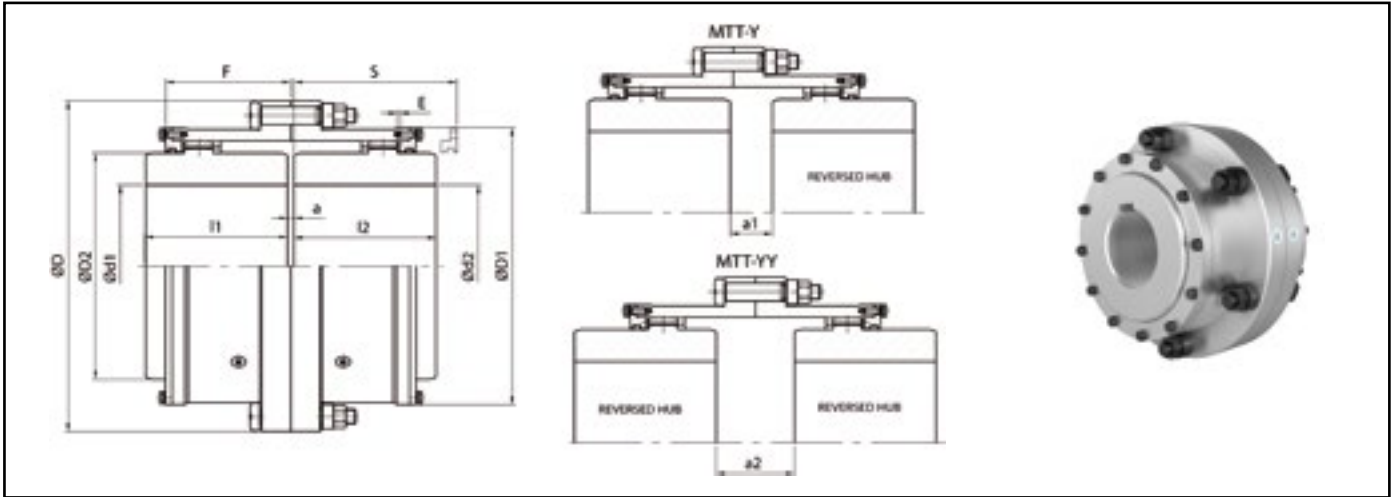

Designation example:
MTT-132 Basic design
MTT-Y-132 One reversed hub
MTT-YY-132 Two reversed hubs

SIZE	MTT		MTT-HD		n MAX (8)	GENERAL DIMENSIONS											WEIGHT Max. (5)	WEIGHT Min. (6)	MOMENT OF INERTIA (5)	GREASE QTY.(7)
	TN NOMINAL (1)	TP MAX (1)	TN NOMINAL (1)	TP MAX (1)		D	D1	D2	d1-d2 (Min-Max) (2)(3)	l1-l2	a	a1	a2	E	F	S(4)				
MTT MTT-HD	Nm	Nm	Nm	Nm	rpm	D	D1	D2	d1-d2 (Min-Max) (2)(3)	l1-l2	a	a1	a2	E	F	S(4)	kg	kg	J (kgm ²)	kg
52	1.780	3.600	2.937	5.940	8.600	119	90,2	69	14-52	43	3	5	7	1,5	39	57	5	4	0,007	0,03
62	2.790	5.520	4.604	9.108	7.000	147	109,6	85	17-62	50	3	8	13	1,5	46	64	9	7	0,018	0,06
78	5.600	11.100	9.240	18.315	5.800	179	135	107	20-78	62	3	14	25	1,5	59,5	80	16	12	0,048	0,13
98	8.500	17.400	14.025	28.710	4.700	220	166	133	26-98	76	5	12	19	2,5	69,5	96	30	21	0,13	0,28
112	14.000	28.200	23.100	46.530	4.200	242	188,6	152	30-112	90	5	24	43	2,5	82,5	108	42	29	0,22	0,28
132	23.000	45.600	37.950	75.240	3.600	284	220	178	35-132	105	6	27	48	3	96	128	69	48	0,56	0,4
156	35.100	69.600	57.915	114.840	3.200	315	252,5	209	70-156	120	6	32	58	3	106,5	140	93	64	0,89	0,6
174	44.400	88.000	73.260	145.200	2.900	340	279	234	85-174	135	8	37	66	4	123	165	118	80	1,37	1
190	68.500	139.600	113.025	230.340	2.600	380	308,5	254	95-190	150	8	50	92	4	139,5	181	164	114	2,38	1,7
210	84.600	167.600	139.590	276.540	2.400	408	341	279	110-210	175	8	52	96	4	154,5	209	216	147	3,60	2,5
233	151.000	304.000	249.150	501.600	2.200	444	372	305	120-233	190	8	58	108	4	166,5	224	261	168	4,99	3,5
275	205.500	407.000	339.075	671.550	2.000	506	427	355	130-275	220	10	72	134	5	193,5	257	408	249	9,96	5,3

From size 174 (included) the coupling is supplied by default with puller holes. If required, puller holes can also be made for smaller sizes.

Setscrews can be included upon request.
Adapted hub length available upon request.

ATEX certifications are available. Please, contact JAURE to define the zone and category.



(1) The torque of the coupling does not include the connection transmission capacity.

(2) Minimum dimensions refer to already machined bore.

For A00 rough bore dimensions contact Jaure.

(3) Max. allowable bore for couplings with DIN 6885/1 keys.

For other types of keys or connections please contact JAURE.

(4) Clearance to align coupling hubs and replacement of sealing rings.

(5) Weight and moment of inertia are given for minimum bore.

(6) Weight is given for maximum bore.

(7) The amount of grease indicated in the catalogue is for guidance only.

For exact amount please refer to coupling instructions.

(8) n MAX speed for balanced couplings. For higher speeds contact Jaure.

Technical modifications reserved

MTS With Single Sleeve

Industrial

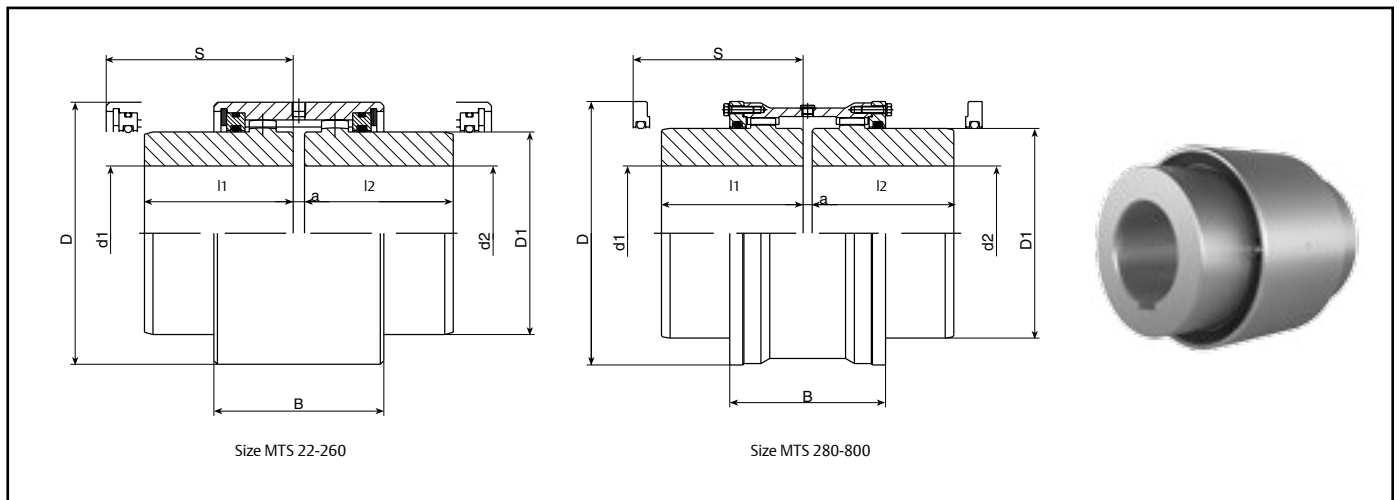

Designation example: **MTS-145**

SIZE	TN NOMINAL (1)	TP MAX (1)	n MAX (8)	GENERAL DIMENSIONS							WEIGHT MAX. (5)	WEIGHT MIN. (6)	MOMENT OF INERTIA (5)	GREASE QTY. (7)
MTS	Nm	Nm	rpm	D	D1	B	d1-d2 (Min-Max) (2)(3)	l1-l2	a	S(4)	kg	kg	J (kgm ²)	kg
22	500	1.000	12.000	56	36	47	8-22	30	4	57	0,88	0,73	0,0003	0,006
32	650	1.300	10.500	70	48	56	10-32	40	4	71	1,80	1,34	0,001	0,011
38	750	1.500	9.500	80	56	68	14-38	45	4	84	2,71	2,02	0,002	0,017
50	1.150	2.300	9.000	96	68	74	18-50	55	6	91	4,68	3,20	0,005	0,024
55	2.600	5.200	7.000	112	80	85	20-58	70	6	108	7,84	5,28	0,011	0,05
70	5.000	10.000	5.600	140	101	106	20-75	80	6	130	14,88	9,65	0,033	0,04
90	8.600	17.200	4.700	164	124	116	25-95	95	8	145	24,41	14,51	0,073	0,06
100	14.000	23.000	4.200	185	143	120	30-105	105	8	150	34,10	20,84	0,128	0,10
125	20.600	41.200	3.600	215	170	130	35-130	120	8	165	53,56	29,71	0,270	0,13
145	33.000	66.000	3.150	255	205	150	45-150	135	10	195	85,52	51,29	0,622	0,14
165	45.600	91.200	2.860	280	216	170	55-165	150	10	215	109,66	64,70	0,963	0,35
185	61.400	122.300	2.580	317	250	190	60-190	170	10	245	163,18	94,56	1,835	0,44
205	80.800	161.600	2.320	345	275	210	70-210	185	12	275	213,28	122,32	2,873	0,53
230	105.500	211.000	2.200	374	300	226	100-230	200	12	295	260,76	152,57	4,263	0,77
260	161.000	322.000	2.000	414	340	266	115-260	230	12	355	374,87	217,46	7,659	1,51
280	220.000	440.000	1.800	465	370	275	140-280	250	16	345	446	355	11,12	2,83
310	250.000	500.000	1.600	505	410	295	160-310	270	16	375	558	441	16,21	3,36
345	320.000	640.000	1.500	548	450	315	180-345	290	16	400	712	557	25	3,54
370	400.000	800.000	1.400	588	490	350	210-370	325	20	450	906	720	37,5	4,83
390	510.000	1.020.000	1.300	640	520	370	230-390	345	20	480	1.100	889	53,25	6,94
420	660.000	1.320.000	1.200	690	560	390	250-420	365	20	510	1.360	1.104	77,5	7,74
460	780.000	1.560.000	1.100	730	600	430	275-460	400	20	560	1.715	1.380	114	9,01
500	1.000.000	2.000.000	1.050	780	650	440	300-500	410	25	570	1.958	1.554	146	10,67
550	1.200.000	2.400.000	950	850	710	460	325-550	430	25	600	2.464	1.942	218	11,03
590	1.600.000	3.200.000	900	910	760	500	350-590	470	25	660	3.050	2.396	308	15,48
620	1.800.000	3.600.000	850	970	810	530	375-620	500	30	700	3.720	2.969	430	15,72
650	1.900.000	3.800.000	800	1.020	840	550	400-650	520	30	730	4.160	3.318	532	18,30
680	2.100.000	4.200.000	750	1.080	890	574	425-680	540	30	755	4.720	3.782	668	24,77
730	2.600.000	5.200.000	700	1.150	950	604	450-730	570	30	800	5.730	4.569	922	27,66
800	3.800.000	7.600.000	660	1.270	1.050	634	475-800	600	30	850	7.520	5.987	1.455	35,76

From size 185 (included) the coupling is supplied by default with puller holes. If required, puller holes can also be made for smaller sizes.

Setscrews can be included upon request.
Adapted hub length available upon request.

ATEX certifications are available. Please, contact JAURE to define the zone and category.



(1) The torque of the coupling does not include the connection transmission capacity.

(2) Minimum dimensions refer to already machined bore.

For A00 rough bore dimensions contact Jaure.

(3) Max. allowable bore for couplings with DIN 6885/1 keys.

For other types of keys or connections please contact JAURE.

(4) Clearance to align coupling hubs and replacement of sealing rings.

(5) Weight and moment of inertia are given for minimum bore.

(6) Weight is given for maximum bore.

(7) The amount of grease indicated in the catalogue is for guidance only.

For exact amount please refer to coupling instructions.

(8) n MAX speed for balanced couplings. For higher speeds contact Jaure.

Technical modifications reserved

MTG/MTG-HD

Basic Design

Industrial

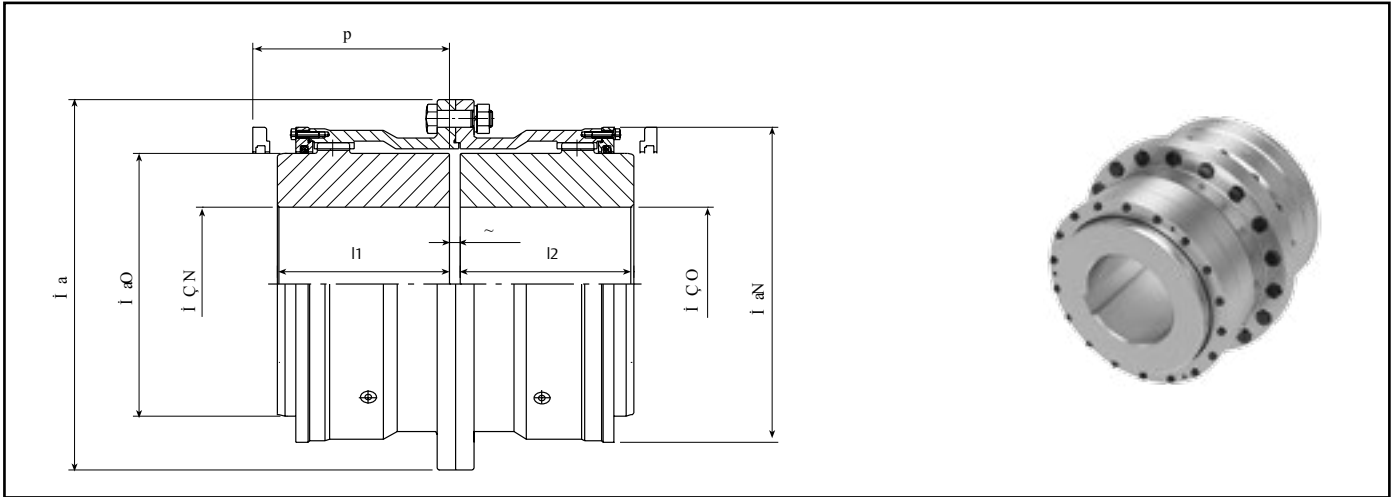

Designation example: **MTG-370**

SIZE	MTG		MTG-HD		n MAX (8)	GENERAL DIMENSIONS							WEIGHT MAX. (5)	WEIGHT MIN. (6)	MOMENT OF INERTIA (5)	GREASE QTY. (7)
	TN NOMINAL (1)	TP MAX (1)	TN NOMINAL (1)	TP MAX (1)		D	D1	D2	d1-d2 (min-max) (2)(3)	l1-l2	a	S(4)				
MTG MTG-HD	Nm	Nm	Nm	Nm	rpm	D	D1	D2	d1-d2 (min-max) (2)(3)	l1-l2	a	S(4)	kg	kg	J (kgm ²)	kg
280	220.000	440.000	363.000	726.000	1.800	540	465	370	140-280	250	16	300	527	346	14,95	4
310	250.000	500.000	412.500	825.000	1.600	585	505	410	160-310	270	16	320	676	442	22,93	5,05
345	320.000	640.000	528.000	1.056.000	1.500	650	548	450	180-345	290	16	340	884	574	36,84	5,87
370	400.000	800.000	660.000	1.320.000	1.400	690	588	490	210-370	325	20	370	1.105	733	53,16	7,16
390	510.000	1.020.000	841.500	1.683.000	1.300	760	640	520	230-390	345	20	400	1.379	957	79,63	10,70
420	660.000	1.320.000	1.089.000	2.178.000	1.200	805	690	560	250-420	365	20	420	1.667	1.154	110	12
460	780.000	1.560.000	1.287.000	2.574.000	1.100	850	730	600	275-460	400	20	450	2.043	1.372	153	13,80
500	1.000.000	2.000.000	1.650.000	3.300.000	1.050	930	780	650	300-500	410	25	490	2.452	1.643	217	16,81
550	1.200.000	2.400.000	1.980.000	3.960.000	950	995	850	710	325-550	430	25	520	3.035	1.991	313	18,62
590	1.600.000	3.200.000	2.640.000	5.280.000	900	1.055	910	760	350-590	470	25	550	3.720	2.413	434	28,29
620	1.800.000	3.600.000	2.970.000	5.940.000	850	1.140	970	810	375-620	500	30	600	4.648	3.145	633	25,19
650	1.900.000	3.800.000	3.135.000	6.270.000	800	1.190	1.020	840	400-650	520	30	630	5.152	3.469	765	33,47
680	2.100.000	4.200.000	3.465.000	6.930.000	750	1.250	1.080	890	425-680	540	30	650	5.954	4.077	990	50,61
730	2.600.000	5.200.000	4.290.000	8.580.000	700	1.300	1.150	950	450-730	570	30	680	6.956	4.634	1.277	54,26
800	3.800.000	7.600.000	6.270.000	12.540.000	660	1.420	1.270	1.050	475-800	600	30	725	9.036	5.971	1.980	72,95
900	5.420.000	10.840.000	8.943.000	17.886.000	590	1.600	1.430	1.180	500-900	670	35	800	13.330	8.670	3.663	91,90
1.000	7.250.000	14.500.000	11.962.500	23.925.000	550	1.740	1.570	1.320	525-1000	740	35	890	17.975	11.130	5.766	112,98
1.100	8.650.000	17.300.000	14.272.500	28.545.000	500	1.880	1.710	1.450	550-1100	800	35	980	23.150	13.930	8.683	135
1.200	10.750.000	21.500.000	17.737.500	35.475.000	480	1.990	1.830	1.580	575-1200	850	35	1.030	28.605	16.680	12.239	162,50

► The coupling is supplied by default with puller holes. If required, puller holes can also be made for smaller sizes.

► Setscrews can be included upon request. ► Adapted hub length available upon request.

► ATEX certifications are available. Please, contact JAURE to define the zone and category.



(1) The torque of the coupling does not include the connection transmission capacity.

(2) Minimum dimensions refer to already machined bore. For A00 rough bore dimensions contact Jaure.

(3) Max. allowable bore for couplings with DIN 6885/1 keys. For other types of keys or connections please contact JAURE.

(4) Clearance to align coupling hubs and replacement of sealing rings.

(5) Weight and moment of inertia are given for minimum bore.

(6) Weight is given for maximum bore.

(7) The amount of grease indicated in the catalogue is for guidance only.

For exact amount please refer to coupling instructions.

(8) n MAX speed for balanced couplings. For higher speeds contact Jaure.

Technical modifications reserved

MTV

Vertical Installation

Industrial

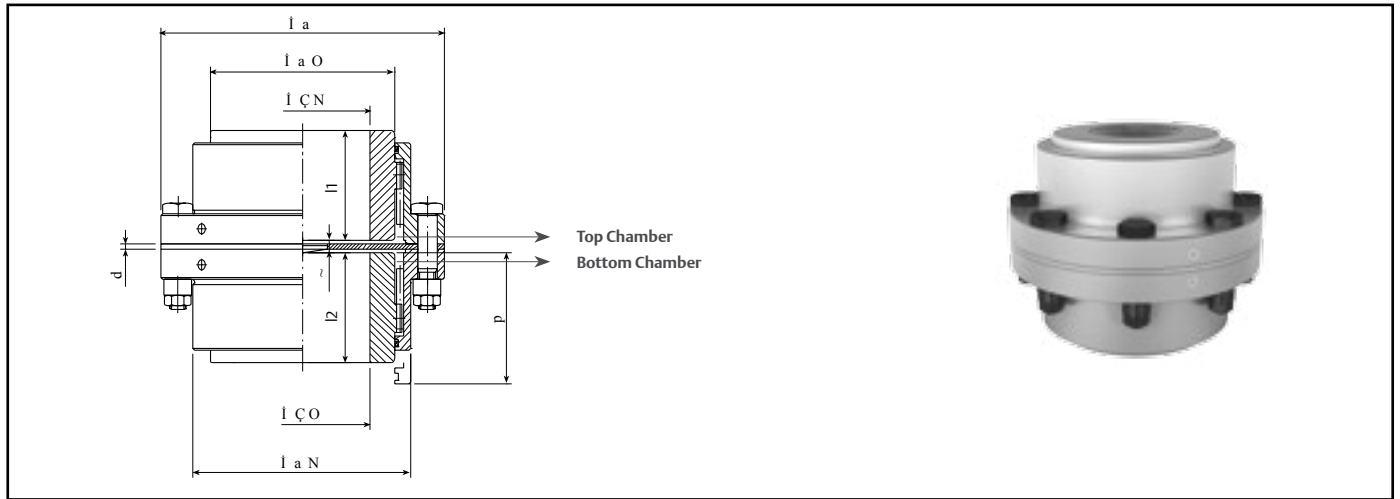

Designation example: MTV-52

SIZE	TN NOMINAL (1)	TP MAX (1)	n MAX (8)	GENERAL DIMENSIONS								WEIGHT Max. (5)	WEIGHT Min. (6)	MOMENT OF INERTIA (5)	GREASE QTY. TOP CHAMBER (7)	GREASE QTY. BOTTOM CHAMBER (7)
				D	D1	D2	d1-d2 (Min-Max) (2)(3)	l1-l2	a	G	S(4)					
MTV	Nm	Nm	rpm	D	D1	D2	d1-d2 (Min-Max) (2)(3)	l1-l2	a	G	S(4)	kg	kg	J (kgm ²)	kg	kg
52	1.780	3.600	8.600	111	82,5	69	14-52	43	6	3	57	4	3	0,005	0,018	0,017
62	2.790	5.520	7.000	141	104,5	85	17-62	50	6	3	64	8	6	0,017	0,038	0,032
78	5.600	11.100	5.800	171	127,5	107	20-78	62	6	3	76	15	11	0,042	0,056	0,046
98	8.500	17.400	4.700	210	156	133	26-98	76	8	3	92	27	18	0,11	0,100	0,068
112	14.000	28.200	4.200	234	181,5	152	30-112	90	8	3	108	40	27	0,21	0,184	0,142
132	23.000	45.600	3.600	274	210,5	178	35-132	105	11	5	125	61	44	0,47	0,279	0,210
156	35.100	69.600	3.200	312	248,5	209	70-156	120	11	5	140	94	64	0,92	0,392	0,298
174	44.400	88.000	2.900	337	274	234	85-174	135	13	5	162	119	81	1,38	0,669	0,511
190	68.500	139.600	2.600	380	308,5	254	95-190	150	13	5	180	170	120	2,56	1,052	0,865
210	84.600	167.600	2.400	405	334	279	110-210	175	14	6	205	217	148	3,71	1,465	1,240
233	151.000	304.000	2.200	444	365,5	305	120-233	190	14	6	218	267	174	5,17	1,996	1,727
275	205.500	407.000	2.000	506	424	355	130-275	220	16	6	252	420	261	10,67	3,097	2,641

From size 174 (included) the coupling is supplied by default with puller holes. If required, puller holes can also be made for smaller sizes.

Setscrews can be included upon request.
Adapted hub length available upon request.

ATEX certifications are available. Please, contact JAURE to define the zone and category.



(1) The torque of the coupling does not include the connection transmission capacity.

(2) Minimum dimensions refer to already machined bore. For A00 rough bore dimensions contact Jaure.

(3) Max. allowable bore for couplings with DIN 6885/1 keys. For other types of keys or connections please consult JAURE.

(4) Clearance to align coupling hubs and replacement of sealing rings.

(5) Weight and moment of inertia are given for minimum bore.

(6) Weight is given for maximum bore.

(7) The amount of grease indicated in the catalogue is for guidance only. For exact amount please refer to coupling instructions.

(8) n MAX speed for balanced couplings. For higher speeds contact Jaure.

MTX/MTX-HD With Spacer

Industrial

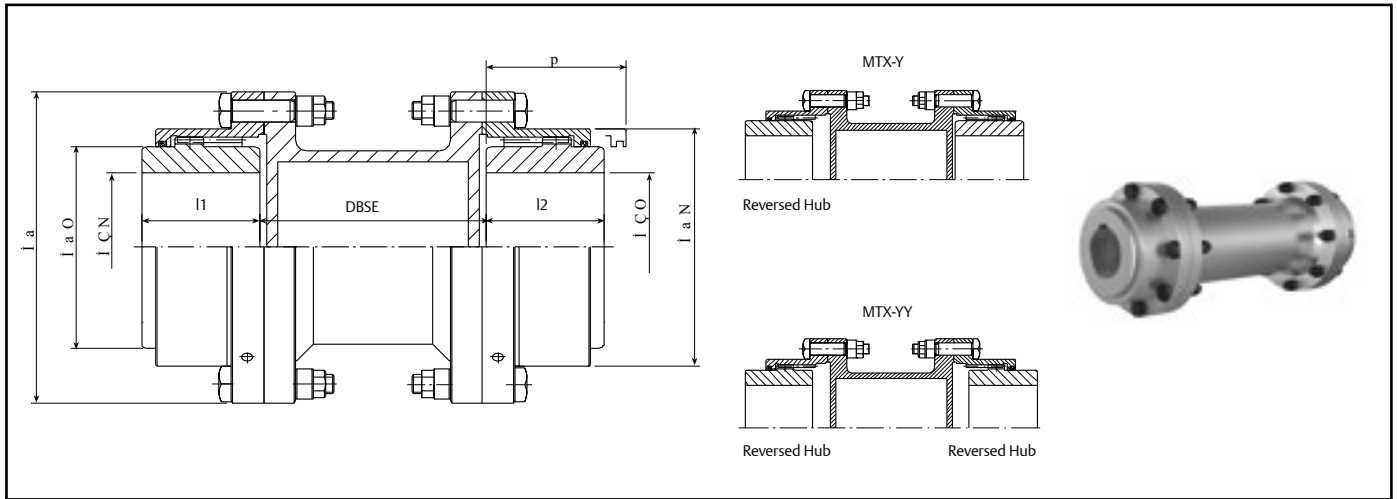

Designation example: MTX-132 / DBSE = 1000(mm) / n=1500rpm
 MTX-Y-132 / DBSE = 1000(mm) / n=1500rpm
 MTX-YY-132 / DBSE = 1000(mm) / n=1500rpm
 Where "n" is the maximum speed

SIZE	MTX		MTX-HD		n MAX (8)	GENERAL DIMENSIONS						WEIGHT MAX. (5)	WEIGHT PER 100MM SPACER	WEIGHT MIN. (6)	MOMENT OF INERTIA (5)	MOMENT OF INERTIA PER 100MM SPACER	GREASE QTY. (7)
	TN NOMINAL (1)	TP MAX (1)	TN NOMINAL (1)	TP MAX (1)		D	D1	D2	d1-d2 (Min-Max) (2)(3)	I1-I2	S(4)						
MTX MTX- HD	Nm	Nm	Nm	Nm	rpm							kg	kg	kg	J (kgm ²)	J (kgm ²)	kg
52	1.780	3.600	2.937	5.940	For max. allowable speed check fig. n° 7 at page 14	111	82,5	69	14-52	43	57	14	0,8	13	0,017	0,0009	0,03
62	2.790	5.520	4.604	9.108		141	104,5	85	17-62	50	64	23	1,0	21	0,047	0,0019	0,06
78	5.600	11.100	9.240	18.315		171	127,5	107	20-78	62	76	36	1,5	31	0,099	0,0033	0,09
98	8.500	17.400	14.025	28.710		210	156	133	26-98	76	92	60	2,4	52	0,27	0,0096	0,14
112	14.000	28.200	23.100	46.530		234	181,5	152	30-112	90	108	80	2,7	67	0,45	0,015	0,29
132	23.000	45.600	37.950	75.240		274	210,5	178	35-132	105	125	113	3,9	106	0,96	0,025	0,42
156	35.100	69.600	57.915	114.840		312	248,5	209	70-156	120	140	169	4,7	139	1,72	0,042	0,6
174	44.400	88.000	73.260	145.200		337	274	234	85-174	135	162	216	6,6	177	2,62	0,074	1,04
190	68.500	139.600	113.025	230.340		380	308,5	254	95-190	150	180	324	10,1	274	5,26	0,17	1,73
210	84.600	167.600	139.590	276.540		405	334	279	110-210	175	205	359	8,0	290	6,48	0,14	2,48
233	151.000	304.000	249.150	501.600		444	365,5	305	120-233	190	218	433	12,2	340	9,32	0,29	3,46
275	205.500	407.000	339.075	671.550		506	424	355	130-275	220	252	659	17,2	500	18,38	0,52	5,31

- From size 174 (included) the coupling is supplied by default with puller holes. If required, puller holes can also be made for smaller sizes.
- Distance to be specified by the customer. DBSE is distance between shaft ends, not between flanges.

- Setscrews can be included upon request.
- Adapted hub length available upon request.

- ATEX certifications are available. Please, contact JAURE to define the zone and category.



(1) The torque of the coupling does not include the connection transmission capacity.

(2) Minimum dimensions refer to already machined bore. For A00 rough bore dimensions contact Jaure.

(3) Max. allowable bore for couplings with DIN 6885/1 keys.

For other types of keys or connections please contact JAURE.

(4) Clearance to align coupling hubs and replacement of sealing rings

(5) Weight and moment of inertia are given for minimum bore and 1m DBSE.

(6) Weight is given for maximum bore and 1m DBSE.

(7) The amount of grease indicated in the catalogue is for guidance only. For exact amount please refer to coupling instructions.

(8) n MAX speed for balanced couplings. For higher speeds contact Jaure.

MTGX/MTGX-HD With Spacer

Industrial

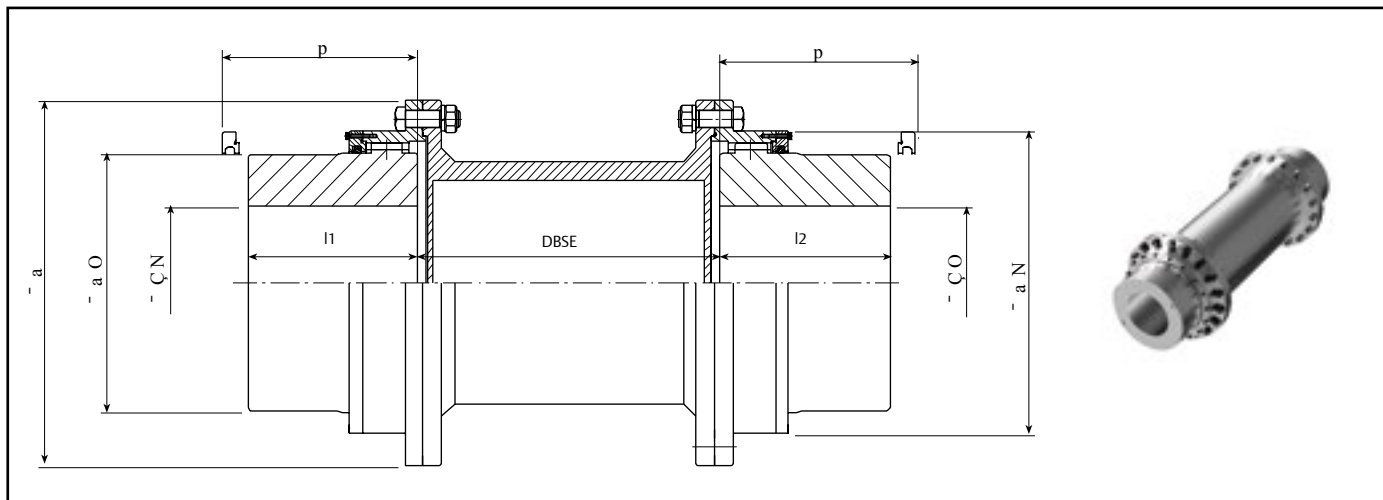

Designation example: **MTGX-370 / DBSE= 1000 (mm) / n= 750rpm**

SIZE	MTGX		MTGX-HD		n MAX (8)	GENERAL DIMENSIONS						WEIGHT MAX. (5)	WEIGHT PER 100MM SPACER	WEIGHT MIN. (6)	MOMENT OF INERTIA (7)	MOMENT OF INERTIA PER 100MM SPACER	GREASE QTY. (7)
	TN NOMINAL (1)	TP MAX (1)	TN NOMINAL (1)	TP MAX (1)		D	D1	D2	d1-d2 (min-max) (2)(3)	l1-l2	S(4)						
MTGX MTGX-HD	Nm	Nm	Nm	Nm	rpm							kg	kg	kg	J (kgm ²)	J (kgm ²)	kg
280	220.000	440.000	363.000	726.000	For max. allowable speed contact JAURE.	540	443	370	140-280	250	300	765	25,0	584	23	0,72	1,73
310	250.000	500.000	412.500	825.000		585	488	410	160-310	270	320	935	27,8	700	33	0,99	2,19
345	320.000	640.000	528.000	1.056.000		650	531	450	180-345	290	340	1.178	31,6	868	53	1,45	2,52
370	400.000	800.000	660.000	1.320.000		690	571	490	210-370	325	370	1.450	36,4	1.078	71	1,64	3,03
390	510.000	1.020.000	841.500	1.683.000		760	627	520	230-390	345	400	1.816	46,2	1.394	108	2,55	3,64
420	660.000	1.320.000	1.089.000	2.178.000		805	673	560	250-420	365	420	2.072	46,4	1.559	142	3,19	4,52
460	780.000	1.560.000	1.287.000	2.574.000		850	717	600	275-460	400	450	2.486	56,2	1.815	193	4,59	4,83
500	1.000.000	2.000.000	1.650.000	3.300.000		930	769	650	300-500	410	490	2.997	61,2	2.188	279	5,90	7,05
550	1.200.000	2.400.000	1.980.000	3.960.000		995	834	710	325-550	430	520	3.563	65,0	2.519	389	8,04	7,38
590	1.600.000	3.200.000	2.640.000	5.280.000		1.055	894	760	350-590	470	550	4.370	81,6	3.062	533	11,06	9,58
620	1.800.000	3.600.000	2.970.000	5.940.000		1.140	944	810	375-620	500	600	5.475	92,5	3.972	781	13,06	11,95
650	1.900.000	3.800.000	3.135.000	6.270.000		1.190	984	840	400-650	520	630	5.940	89,3	4.257	929	14,52	14,30
680	2.100.000	4.200.000	3.465.000	6.930.000		1.250	1.059	890	425-680	540	650	6.810	94,9	4.934	1.188	17,39	20,26
730	2.600.000	5.200.000	4.290.000	8.580.000		1.300	1.109	950	450-730	570	680	7.758	106	5.436	1.493	24,22	21,56
800	3.800.000	7.600.000	6.270.000	12.540.000		1.420	1.224	1.050	475-800	600	725	9.990	141,7	6.924	2.270	38,80	26,62
900	5.420.000	10.840.000	8.943.000	17.886.000		1.600	1.384	1.180	500-900	670	800	14.308	176,1	9.682	4.084	62,50	35,18
1.000	7.250.000	14.500.000	11.962.500	23.925.000		1.740	1.524	1.320	525-1000	740	890	18.746	198,3	12.136	6.265	89,19	43,69
1.100	8.650.000	17.300.000	14.272.500	28.545.000	1.880	1.664	1.450	550-1100	800	980	23.940	230	14.988	9.238	118,66	55,48	
1.200	10.750.000	21.500.000	17.737.500	35.475.000	1.990	1.784	1.580	575-1200	850	1.030	29.217	254,1	17.590	12.806	159,84	54,62	

► The coupling is supplied by default with puller holes. If required, puller holes can also be made for smaller sizes.
► Distance to be specified by the customer. DBSE is distance between shafts ends, not between flanges.

► Setscrews can be included upon request.
► Adapted hub length available upon request.

► ATEX certifications are available. Please, contact JAURE to define the zone and category.



(1) The torque of the coupling does not include the connection transmission capacity.

(2) Minimum dimensions refer to already machined bore.

For A00 rough bore dimensions contact Jaure.

(3) Max. allowable bore for couplings with DIN 6885/1 keys.

For other types of keys or connections please contact JAURE.

(4) Clearance to align coupling hubs and replacement of sealing rings.

(5) Weight and moment of inertia are given for minimum bore and 1m DBSE.

(6) Weight is given for maximum bore and 1m DBSE.

(7) The amount of grease indicated in the catalogue is for guidance only.

For exact amount please refer to coupling instructions.

(8) n MAX speed for balanced couplings. For higher speeds contact Jaure.

Technical modifications reserved

MTD/MTD-HD With Floating Shaft

Industrial

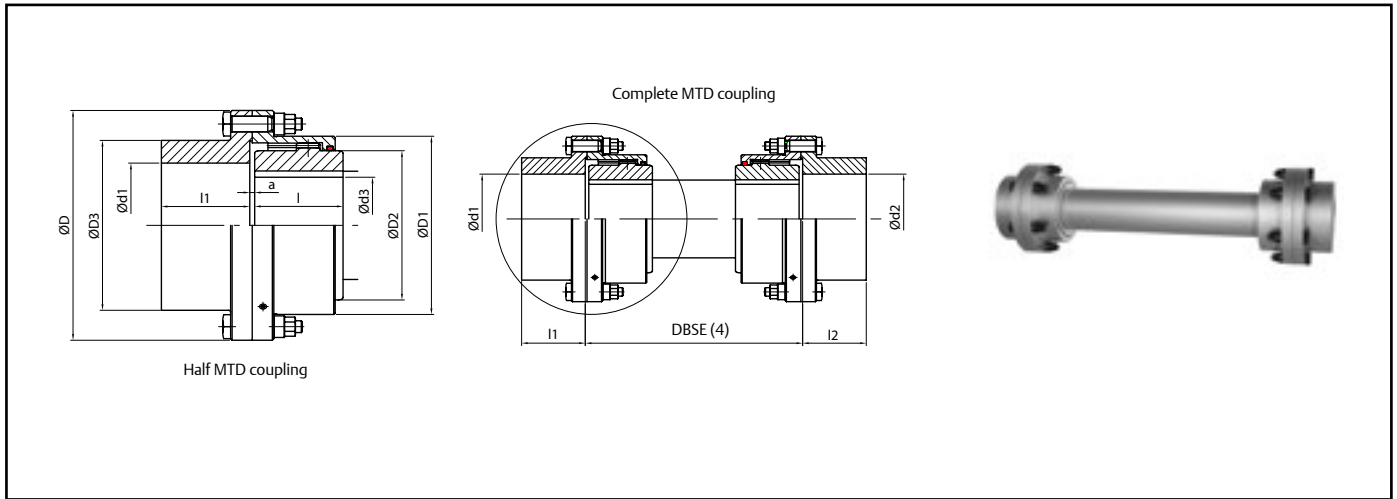

Designation example: **MTD-132 / DBSE=1200 (mm) / n = 1500 rpm**

SIZE	MTD		MTD-HD		n MAX (8)	GENERAL DIMENSIONS							WEIGHT MAX. (5)	WEIGHT PER 100MM SHAFT	WEIGHT MIN. (6)	MOMENT OF INERTIA (5)	MOMENT OF INERTIA PER 100MM SHAFT	GREASE QTY. (7)	
	TN NOMINAL (1)	TP MAX (1)	TN NOMINAL (1)	TP MAX (1)		D	D1	D2	D3	d3 (Min-Max) (2)(3)	d1-d2 (Min-Max) (2)(3)	l-l1-l2							a
MTD	Nm	Nm	Nm	Nm	rpm								kg	kg	kg	J (kgm ²)	J (kgm ²)	kg	
MTD-HD																			
52	1.780	3.600	2.937	5.940	For max. allowable speed check fig. n° 8 at page 14	111	82,5	69	80	14-52	14-55	43	3	27	2,0	25	0,018	0,001	0,03
62	2.790	5.520	4.604	9.108		141	104,5	85	100	17-62	17-70	50	3	42	2,8	40	0,048	0,002	0,06
78	5.600	11.100	9.240	18.315		171	127,5	107	125	20-78	20-90	62	3	68	4,4	63	0,117	0,004	0,09
98	8.500	17.400	14.025	28.710		210	156	133	148	26-98	26-105	76	5	111	6,8	103	0,30	0,01	0,14
112	14.000	28.200	23.100	46.530		234	181,5	152	173	30-112	30-120	90	5	150	8,6	137	0,54	0,01	0,29
132	23.000	45.600	37.950	75.240		274	210,5	178	204	35-132	35-145	105	6	227	12,3	206	1,18	0,03	0,42
156	35.100	69.600	57.915	114.840		312	248,5	209	242	70-156	70-170	120	6	321	17,0	292	2,28	0,06	0,60
174	44.400	88.000	73.260	145.200		337	274	234	268	85-174	85-190	135	8	404	21,1	366	3,47	0,09	1,04
190	68.500	139.600	113.025	230.340		380	308,5	254	302	95-190	95-215	150	8	535	24,9	485	6,13	0,13	1,73
210	84.600	167.600	139.590	276.540		405	334	279	327	110-210	110-230	175	8	669	30,4	600	9,01	0,19	2,48
233	151.000	304.000	249.150	501.600		444	365,5	305	354	120-233	120-250	190	8	820	37,3	727	12,18	0,28	3,46
275	205.500	407.000	339.075	671.550		506	424	355	410	130-275	130-290	220	10	1.199	51,1	1.039	25,66	0,53	5,31

From size 174 (included) the coupling is supplied by default with puller holes. If required, puller holes can also be made for smaller sizes.

Setscrews can be included upon request.
Adapted hub length available upon request.

ATEX certifications are available. Please, contact JAURE to define the zone and category.



(1) The torque of the coupling does not include the connection transmission capacity.

(2) Minimum dimensions refer to already machined bore. For A00 rough bore dimensions contact Jaure.

(3) Max. allowable bore for couplings with DIN 6885/1 keys. For other types of keys or connections please contact JAURE.

(4) Distance to be specified by the customer. DBSE is distance between shafts ends, not between flanges.

(5) Weight and moment of inertia are given for minimum bore and 1m DBSE for full MTD coupling.

(6) Weight is given for maximum bore and 1m DBSE for full coupling.

(7) The amount of grease indicated in the catalogue is for guidance only. For exact amount please refer to coupling instructions.

(8) n MAX speed for balanced couplings. For higher speeds contact Jaure.

Technical modifications reserved

MTGD / MTGD-HD With Intermediate Floating Shaft

Industrial

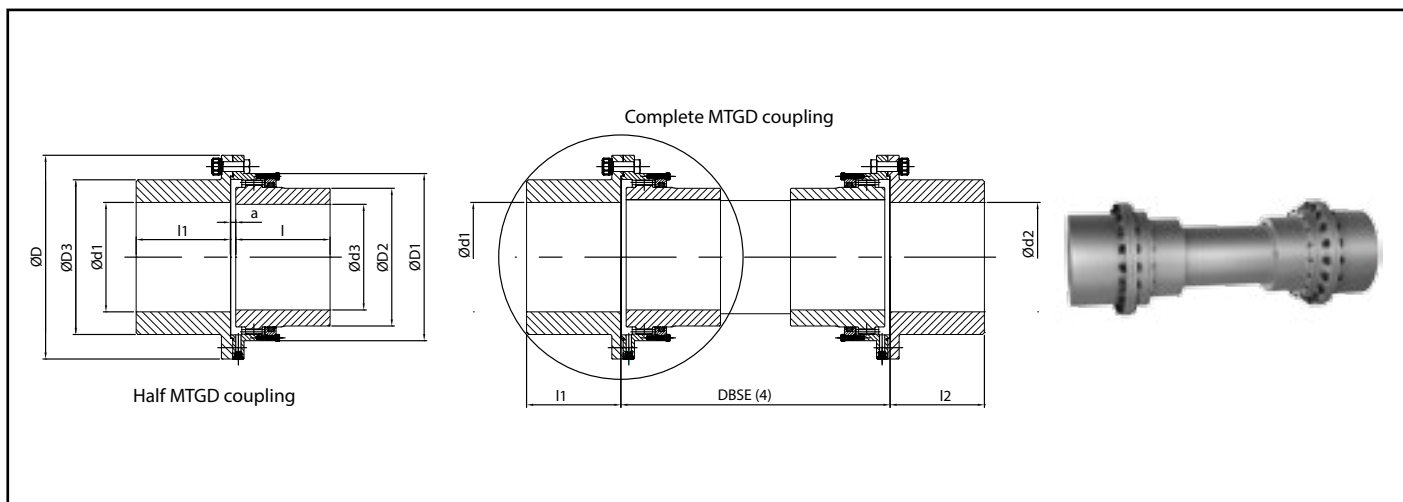

Designation example: **MTGD-370 / DBSE=1200 (mm) / n = 750 rpm**

SIZE	MTGD		MTGD-HD		n MAX (8)	GENERAL DIMENSIONS							WEIGHT MAX. (5)	WEIGHT PER 100MM SHAFT	WEIGHT MIN. (6)	MOMENT OF INERTIA (5)	MOMENT OF INERTIA PER 100MM SHAFT	GREASE QTY. (7)	
	TN NOMINAL (1)	TP MAX (1)	TN NOMINAL (1)	TP MAX (1)		D	D1	D2	D3	d1-d2 (Min- Max(2)(3))	d3 (Min-Max (2)(3))	l-l1-l2							a
MTGD MTGD- HD	Nm	Nm	Nm	Nm	rpm								kg	kg	kg	J (kgm ²)	J (kgm ²)	kg	
280	220.000	440.000	363.000	726.000	For max. allowable speed contact Jaure	540	465	370	410	140-290	140-280	250	16	1.980	55,5	1.781	33	0,624	1,73
310	250.000	500.000	412.500	825.000		585	505	410	460	160-350	160-310	270	16	2.470	67,1	2.147	51	0,914	2,19
345	320.000	640.000	528.000	1.056.000		650	548	450	500	180-380	180-345	290	16	3.072	82,1	2.671	79	1,368	2,52
370	400.000	800.000	660.000	1.320.000		690	588	490	540	210-410	210-370	325	20	3.632	93,8	3.135	109	1,78	3,03
390	510.000	1.020.000	841.500	1.683.000		760	640	520	590	230-450	230-390	345	20	4.258	103,6	3.621	155	2,18	3,64
420	660.000	1.320.000	1.089.000	2.178.000		805	690	560	630	250-480	250-420	365	20	5.021	122,1	4.266	210	3,02	4,52
460	780.000	1.560.000	1.287.000	2.574.000		850	730	600	680	275-520	275-460	400	20	6.056	145,0	5.096	296	4,26	4,83
500	1.000.000	2.000.000	1.650.000	3.300.000		930	780	650	730	300-560	300-500	410	25	7.161	169,9	6.031	418	5,85	7,05
550	1.200.000	2.400.000	1.980.000	3.960.000		995	850	710	790	325-600	325-550	430	25	8.646	203,8	7.297	592	8,42	7,38
590	1.600.000	3.200.000	2.640.000	5.280.000		1.055	910	760	850	350-650	350-590	470	25	10.316	237,0	8.577	822	11,39	9,58
620	1.800.000	3.600.000	2.970.000	5.940.000		1.140	970	810	890	375-680	375-620	500	30	11.848	260,5	9.864	1.096	13,76	11,95
650	1.900.000	3.800.000	3.135.000	6.270.000		1.190	1.020	840	930	400-710	400-650	520	30	13.094	285,1	10.887	1.331	16,48	14,30
680	2.100.000	4.200.000	3.465.000	6.930.000		1.250	1.080	890	1.010	425-770	425-680	540	30	15.177	319,6	12.432	1.777	20,71	20,26
730	2.600.000	5.200.000	4.290.000	8.580.000		1.300	1.150	950	1.060	450-810	450-730	570	30	17.501	375,1	14.313	2.276	28,53	21,56
800	3.800.000	7.600.000	6.270.000	12.540.000		1.420	1.270	1.050	1.170	475-900	475-800	600	30	21.610	435,0	17.286	3.410	38,37	26,62
900	5.420.000	10.840.000	8.943.000	17.886.000		1.600	1.430	1.180	1.330	500-900	500-900	670	35	29.654	556,4	23.292	6.125	62,77	35,18
1.000	7.250.000	14.500.000	11.962.500	23.925.000		1.740	1.570	1.320	1.470	525-1000	525-1000	740	35	29.506	692,7	20.575	7.999	97,30	43,69
1.100	8.650.000	17.300.000	14.272.500	28.545.000		1.880	1.710	1.450	1.610	550-1100	550-1100	800	35	36.272	829,6	24.332	10.894	140	55,48
1.200	10.750.000	21.500.000	17.737.500	35.475.000		1.990	1.830	1.580	1.730	575-1200	575-1200	850	35	43.404	978,8	28.607	16.590	194	54,62

► The coupling is supplied by default with puller holes. If required, puller holes can also be made for smaller sizes.

► Setscrews can be included upon request.
► Adapted hub length available upon request.

► ATEX certifications are available. Please, contact JAURE to define the zone and category.



(1) The torque of the coupling does not include the connection transmission capacity.

(2) Minimum dimensions refer to already machined bore. For A00 rough bore dimensions contact Jaure.

(3) Max. allowable bore for couplings with DIN 6885/1 keys. For other types of keys or connections please consult JAURE.

(4) Distance to be specified by the customer.

DBSE is distance between shafts ends, not between flanges.

(5) Weight and moment of inertia are given for minimum bore and 2.5 m DBSE for full MTGD coupling.

(6) Weight is given for maximum bore and 2.5 m DBSE for full MTGD coupling.

(7) The amount of grease indicated in the catalogue is for guidance only. For exact amount please refer to coupling instructions.

(8) n MAX speed for balanced couplings. For higher speeds contact Jaure.

Technical modifications reserved

MTFF

With Intermediate Brake Disc and axially limited

Industrial

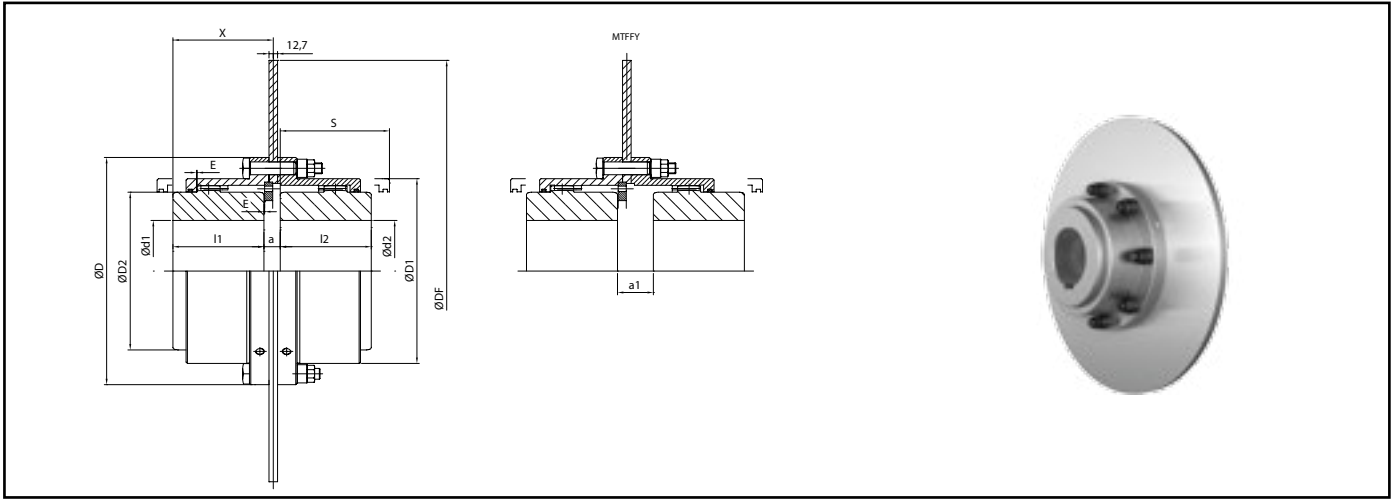

Designation example: MTFF-132 / DF = 625 (mm) / b = 12.7 (mm) / n = 1800 (rpm)

Where "n" is the maximum speed

SIZE	TN NOMINAL (1)	TP MAX (1)	n MAX (8)(9)	GENERAL DIMENSIONS											WEIGHT Max. (5)	WEIGHT Min. (6)	MOMENT OF INERTIA (5)	GREASE QTY. (7)
				D	D1	D2	DF	X	E	d1-d2 (Min-Max) (2)(3)	I1-I2	a	a1	S(3)				
MTFF	Nm	Nm	rpm	D	D1	D2	DF	X	E	d1-d2 (Min-Max) (2)(3)	I1-I2	a	a1	S(3)	kg	kg	J (kgm ²)	kg
52	1.800	3.600	4.200 3.500	111	82,5	69	215 315	52	0,5	14-52	43	17	19	57	9 11	8 10	0,043 0,101	0,043
62	2.760	5.520	3.500 3.100 2.800	141	104,5	85	315 355 395	59	0,5	17-62	50	17	22	64	15 17 20	13 15 18	0,112 0,171 0,254	0,086
78	5.550	11.100	2.800 2.500 2.200 2.000	171	127,5	107	395 445 495 550	71	0,5	20-78	62	17	28	76	25 29 32 37	21 25 28 33	0,277 0,422 0,626 0,934	0,122
98	8.700	17.400	2.500 2.200 2.000 1.800	210	156	133	445 495 550 625	87	0,5	26-98	76	20	27	92	40 44 49 55	32 36 41 47	0,492 0,695 1,00 1,60	0,174
112	14.100	28.200	2.200 2.000 1.800 1.600	234	181,5	152	495 550 625 705	101	0,5	30-112	90	20	39	108	57 61 68 76	44 48 55 63	0,78 1,09 1,69 2,61	0,344
132	22.800	45.600	1.800 1.600 1.400	274	210,5	178	625 705 795	116	1	35-132	105	21	42	125	86 95 105	70 79 89	1,94 2,86 4,35	0,497
156	34.800	69.600	1.800 1.600 1.400	312	248,5	209	625 705 795	131	1	70-156	120	21	47	140	119 127 138	89 97 108	2,36 3,28 4,78	0,696
174	44.000	88.000	1.800 1.600 1.400	337	274	234	625 705 795	149	1	85-174	135	24	53	162	142 150 161	104 112 123	2,80 3,73 5,22	1,17
190	69.800	139.600	1.800 1.300 1.200	380	308,5	254	625 705 795	163	1	95-190	150	24	66	180	192 200 211	142 150 161	3,95 4,87 6,36	1,92
210	83.800	167.600	1.600 1.400	405	334	279	705 795	188	1	110-210	175	24	68	205	245 256	176 187	5,97 7,46	2,70
233	152.000	304.000	1.400	444	365,5	305	795	203	1	120-233	190	24	74	218	304	211	8,85	3,74

From size 174 (included) the coupling is supplied by default with puller holes. If required, puller holes can also be made for smaller sizes.
Modified brake disc dimensions on request.

Setscrews can be included upon request.
Adapted hub length available upon request.

ATEX certifications are available. Please, contact JAURE to define the zone and category.



(1) When calculating the nominal torque of the coupling neither the connection nor the braking system are considered. For more details, please, contact JAURE.

(2) Minimum dimensions refer to already machined bore. For A00 rough bore dimensions contact Jaure.

(3) Max. allowable bore for couplings with DIN 6885/1 keys. For other types of keys or connections please contact JAURE.

(4) Clearance to align coupling hubs and replacement of sealing rings.

(5) Weight and moment of inertia are given for minimum bore.

(6) Weight is given for maximum bore.

(7) The amount of grease indicated in the catalogue is for guidance only.

For exact amount please refer to coupling instructions.

(8) Maximum speed calculated according to standard brake material (S 355).

For higher speed, please contact JAURE.

(9) n MAX speed for balanced couplings. For higher speeds contact Jaure.

Technical modifications reserved

MTFS With Side Brake Disc

Industrial

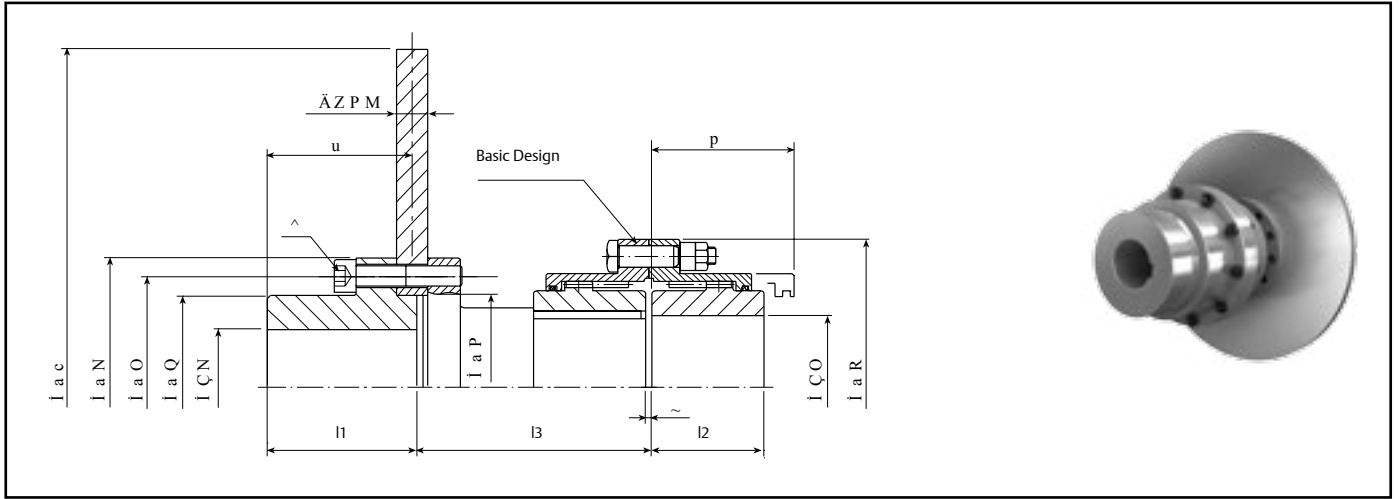

Designation example: MTFS-132 / D = 625 (mm) / b = 30 (mm) / n = 1200 (rpm)

Where "n" is the maximum speed

SIZE	TN NOMINAL (1)	TP MAX (1)	n MAX (8)(10)	GENERAL DIMENSIONS													BOLTS DATA pos A		WEIGHT MAX. (5)	WEIGHT MIN. (6)	MOMENT OF INERTIA (5)	GREASE QTY. (7)
				DF	D1	D2	D3 (H7/f8)	D4	D5	d1(Max) (3)	d2 (Min-Max) (2)(3)	l1	l2	l3 (9)	S(4)	X	Z-M	Nm				
62	2.790	5.520	3.500	315	124	105	85	82	141	50	17-62	107	50	117	64	102	9-M10	49	34	31	0,253	0,06
				355	145	125	105	100	70	107	107	117	102	9-M12	86	42	38	0,402				
				2.800	395	165	140	115	110	107	107	117	102	9-M14	135	50	46	0,612				
				2.500	445	175	146	120	112	70	140	140	117	135	12-M16	210	63	58	0,972			
78	5.600	11.100	2.800	395	165	140	115	110	171	70	20-78	107	62	117	76	102	9-M14	135	57	51	0,634	0,09
				445	175	146	120	112	70	140	140	130	135	12-M16	210	70	64	0,996				
				2.200	495	218	190	160	155	100	140	140	145	135	12-M18	290	92	82	1,565			
				2.000	550	218	190	160	155	100	140	140	145	135	12-M18	290	104	93	2,3			
98	8.500	17.400	2.500	445	175	146	120	112	210	70	26-98	140	76	145	92	135	12-M16	210	82	74	1,063	0,14
				2.200	495	218	190	160	155	100	140	140	164	135	12-M18	290	106	93	1,640			
				2.000	550	218	190	160	155	100	140	140	164	135	12-M18	290	117	104	2,367			
				1.800	625	238	205	170	168	105	140	140	164	135	12-M20	410	140	126	3,85			
112	14.000	28.200	2.200	495	218	190	160	155	234	100	30-112	140	90	180	108	135	12-M18	290	120	106	1,73	0,29
				2.000	550	218	190	160	155	100	140	180	180	135	12-M18	290	131	117	2,46			
				1.800	625	238	205	170	168	105	140	180	180	135	12-M20	410	154	139	3,94			
				1.600	705	268	230	195	190	120	140	196	196	135	12-M22	550	185	167	6,27			
132	23.000	45.600	1.800	625	238	205	170	168	274	105	35-132	140	105	196	125	135	12-M20	410	178	160	4,18	0,42
				1.600	705	268	230	195	190	120	140	196	196	135	12-M22	550	195	189	6,51			
				1.400	795	300	260	220	216	135	140	196	196	135	12-M24	710	250	225	10,27			
				1.800	625	238	205	170	168	105	140	223	223	135	12-M20	410	216	192	4,60			
156	35.100	69.600	1.600	705	268	230	195	190	312	120	70-156	140	120	223	140	135	12-M20	410	248	192	6,93	0,60
				1.600	705	268	230	195	190	120	140	223	223	135	12-M22	550	248	221	6,93			
				1.400	795	300	260	220	216	135	140	223	223	135	12-M24	710	287	257	10,69			
				1.800	625	238	205	170	168	105	140	238	238	135	12-M22	550	281	250	7,39			
174	44.400	88.000	1.600	705	268	230	195	190	337	120	85-174	140	135	238	162	135	12-M22	550	281	250	11,15	1,04
				1.400	795	300	260	220	216	135	140	238	238	135	12-M24	710	320	286	11,15			

- From size 174 (included) the coupling is supplied by default with puller holes. If required, puller holes can also be made for smaller sizes.
- Modified brake disc dimensions on request.

- Anti-fall system version can be supplied on demand.
- Setscrews can be included upon request.
- Adapted hub length available upon request.

- ATEX certifications are available. Please, contact JAURE to define the zone and category.



(1) When calculating the nominal torque of the coupling neither the connection nor the braking system are considered.

For more details, please, contact JAURE.

(2) Minimum dimensions refer to already machined bore.

For A00 rough bore dimensions contact Jaure.

(3) Max. allowable bore for couplings with DIN 6885/1 keys.

For other types of keys or connections please contact JAURE.

(4) Clearance to align coupling hubs and replacement of sealing rings.

(5) Weight and moment of inertia are given for minimum bore.

(6) Weight is given for maximum bore.

(7) The amount of grease indicated in the catalogue is for guidance only.

(8) Maximum speed calculated according to standard brake material (S355).

For higher speed, please contact JAURE.

(9) l3 can be supplied with different length on demand.

For exact amount please refer to coupling instructions.

(10) n MAX speed for balanced couplings. For higher speeds contact Jaure.

MTF With Intermediate Brake Drum

Industrial

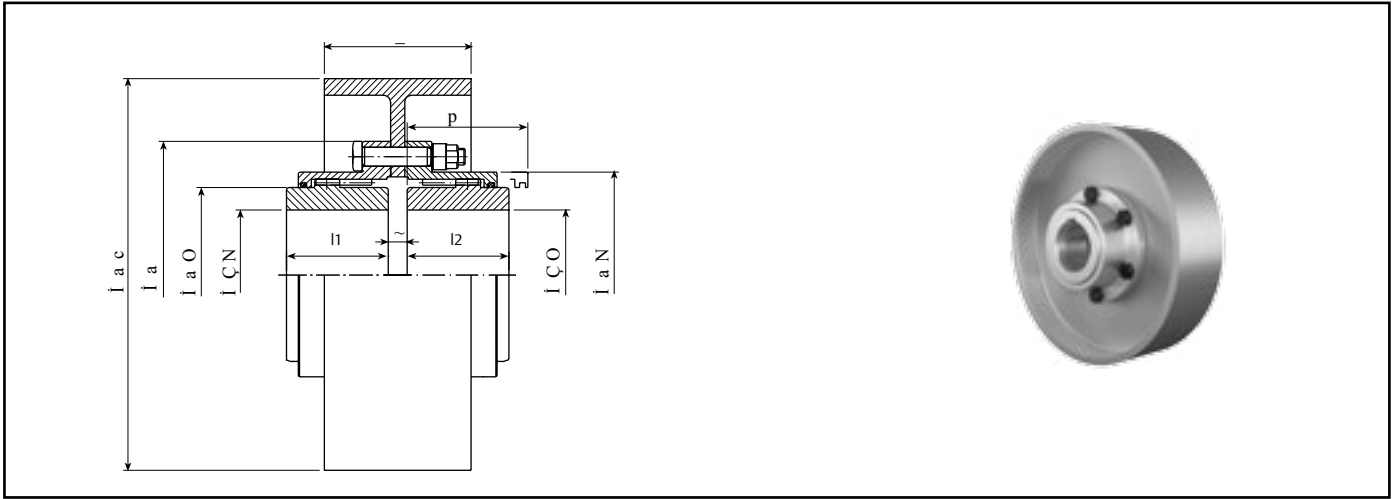

Designation example: MTF-132 / DF = 450 (mm) / n = 1200 (rpm)
Where "n" is the maximum speed

SIZE	TN NOMINAL (1)	TP MAX (1)	n MAX (8)(9)	GENERAL DIMENSIONS									WEIGHT MAX. (5)	WEIGHT MIN. (6)	MOMENT OF INERTIA (5)	GREASE QTY. (7)
				D	D1	D2	DF	B	d1-d2 (Min-Max) (2)(3)	l1-l2	a	S(4)				
MTF	Nm	Nm	rpm	D	D1	D2	DF	B	d1-d2 (Min-Max) (2)(3)	l1-l2	a	S(4)	kg	kg	J (kgm ²)	kg
52	1.780	3.600	2.850	111	82,5	69	200	75	14-52	43	13	57	9	8	0,045	0,04
62	2.790	5.520	2.850 2.300 1.800	141	104,5	85	200 250 315	75 95 118	17-62	50	13 13 15	64	13 17 24	11 14 22	0,056 0,119 0,326	0,08 0,08 0,08
78	5.600	11.100	2.300 1.800 1.650 1.450	171	127,5	107	250 315 350 400	95 118 130 150	20-78	62	13 15 15 19	76	23 31 35 50	19 26 30 45	0,144 0,351 0,519 1,112	0,12 0,12 0,12 0,13
98	8.500	17.400	1.800 1.650 1.450	210	156	133	315 350 400	118 130 150	26-98	76	17 19 19	92	42 47 60	33 39 51	0,411 0,604 1,152	0,17 0,18 0,18
112	14.000	28.200	1.800 1.650 1.450 1.300	234	181,5	152	315 350 400 450	118 130 150 170	30-112	90	17 19 19 19	108	54 60 72 79	41 47 59 66	0,50 0,70 1,24 1,77	0,34 0,35 0,35 0,35
132	23.000	45.600	1.450 1.300 1.150	274	210,5	178	400 450 500	150 170 190	35-132	105	20 20 20	125	90 97 107	73 80 90	1,48 2,01 2,88	0,51 0,51 0,51
156	35.100	69.600	1.150 1.100 1.000	312	248,5	209	500 530 630	190 195 236	70-156	120	21 21 24	140	142 150 192	112 120 163	3,37 4,10 8,68	0,71 0,71 0,73
174	44.400	88.000	1.150 1.100 1.000 800	337	274	234	500 530 630 710	190 195 236 265	85-174	135	23 23 26 26	162	168 176 218 247	130 138 180 208	3,85 4,58 9,16 14,07	1,18 1,18 1,21 1,21

From size 174 (included) the coupling is supplied by default with puller holes. If required, puller holes can also be made for smaller sizes.
Anti-fall system version can be supplied on demand.
Setscrews can be included upon request.

Adapted hub length available upon request.

ATEX certifications are available. Please, contact JAURE to define the zone and category.



(1) When calculating the nominal torque of the coupling neither the connection nor the braking system are considered.

For more details, please, contact JAURE.

(2) Minimum dimensions refer to already machined bore.

For A00 rough bore dimensions contact Jaure.

(3) Max. allowable bore for couplings with DIN 6885/1 keys.

For other types of keys or connections please contact JAURE.

(4) Clearance to align coupling hubs and replacement of sealing rings.

(5) Weight and moment of inertia are given for minimum bore.

(6) Weight is given for maximum bore.

(7) The amount of grease indicated in the catalogue is for guidance only.

For exact amount please refer to coupling instructions.

(8) Maximum speed calculated according to standard brake material

(EN-GJL-250) For higher speed, please contact JAURE.

(9) n MAX speed for balanced couplings. For higher speeds contact Jaure.

Technical modifications reserved

MTFE

With Side Brake Drum

Industrial

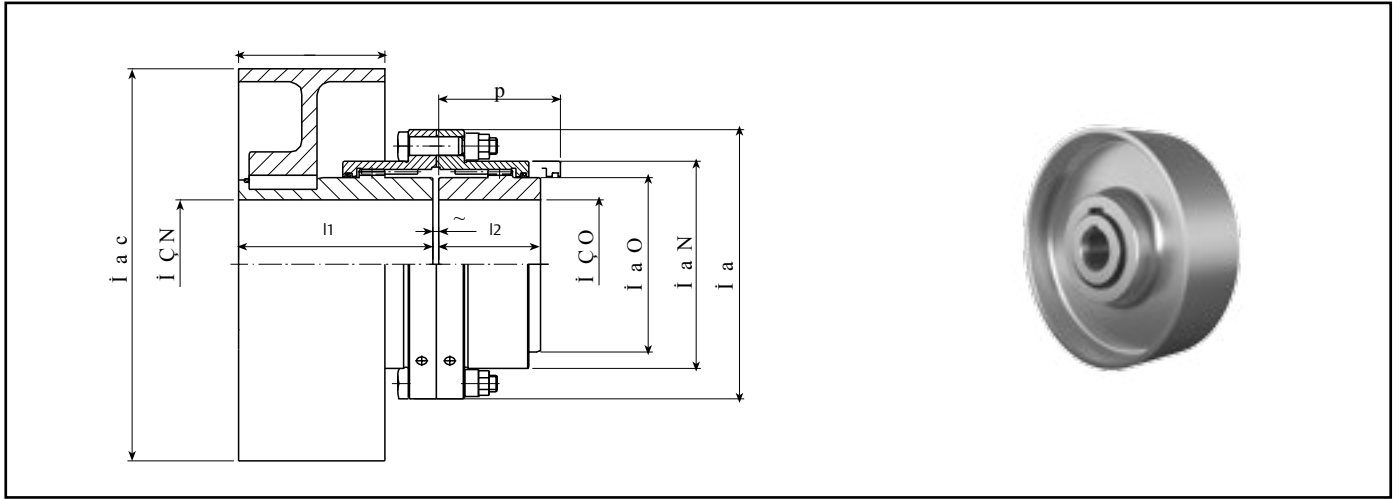

Designation example: MTFE-132 / DF = 450 (mm) n = 1200 (rpm)
Where "n" is the maximum speed.

SIZE	TN NOMINAL (1)	TP MAX (1)	n MAX (8)(10)	GENERAL DIMENSIONS										WEIGHT MAX. (5)	WEIGHT MIN. (6)	MOMENT OF INERTIA (5)	GREASE QTY. (7)
				D	D1	D2	DF	B	d1-d2 (Min-Max) (2)(3)	l1 (9)	l2	a	S(4)				
MTFE	Nm	Nm	rpm	D	D1	D2	DF	B	d1-d2 (Min-Max) (2)(3)	l1 (9)	l2	a	S(4)	kg	kg	J (kgm ²)	kg
52	1.780	3.600	2.850	111	82,5	69	200	75	14-52	105	43	3	57	11	8	0,040	0,03
62	2.790	5.520	2.850 2.300 1.800	141	104,5	85	200 250 315	75 95 118	17-62	115 125 140	50	3 3 3	64	17 21 28	13 18 24	0,060 0,126 0,296	0,06
78	5.600	11.100	2.300 1.800 1.650 1.450	171	127,5	107	250 315 350 400	95 118 130 150	20-78	130 145 145 160	62	3 3 3 3	76	30 39 45 59	24 32 37 51	0,166 0,359 0,550 1,060	0,09
98	8.500	17.400	1.800 1.650 1.450	210	156	133	315 350 400	118 130 150	26-98	155 155 170	76	5 5 5	92	55 61 76	42 49 63	0,460 0,670 1,190	0,14
112	14.000	28.200	1.800 1.650 1.450 1.300	234	181,5	152	315 350 400 450	118 130 150 170	30-112	155 155 170 180	90	5 5 5 5	108	66 71 88 107	48 54 69 88	0,54 0,74 1,28 2,12	0,29
132	23.000	45.600	1.450 1.300 1.150	274	210,5	178	400 450 500	150 170 190	35-132	200 210 220	105	6 6 6	125	119 137 158	88 105 126	1,59 2,42 3,76	0,42
156	35.100	69.600	1.150 1.100 1.000	312	248,5	209	500 530 630	190 195 236	70-156	220 220 250	120	6 6 6	140	181 192 239	144 151 195	4,16 4,90 9,16	0,60
174	44.400	88.000	1.150 1.100 1.000 800	337	274	234	500 530 630 710	190 195 236 265	85-174	235 235 265 280	135	8 8 8 8	162	225 231 273 304	172 179 216 245	4,96 5,69 9,85 14,66	1,04

From size 174 (included) the coupling is supplied by default with puller holes. If required, puller holes can also be made for smaller sizes.
Anti-fall system version can be supplied on demand.
Setscrews can be included upon request.

Adapted hub length available upon request.

ATEX certifications are available. Please, contact JAURE to define the zone and category.



(1) When calculating the nominal torque of the coupling neither the connection nor the braking system are considered.

For more details, please, contact JAURE.

(2) Minimum dimensions refer to already machined bore.

For A00 rough bore dimensions contact JAURE.

(3) Max. allowable bore for couplings with DIN 6885/1 keys.

For other types of keys or connections please contact JAURE.

(4) Clearance to align coupling hubs and replacement of sealing rings.

(5) Weight and moment of inertia are given for minimum bore.

(6) Weight is given for maximum bore.

(7) The amount of grease indicated in the catalogue is for guidance only.

For exact amount please refer to coupling instructions.

(8) When calculating the maximum allowed speed, we just consider the type of material of the brake drums EN-GJL-250. For other speed or

materials, please, contact JAURE.

(9) l1 can be supplied with different length on demand.

(10) n MAX speed for balanced couplings. For higher speeds contact JAURE.

MTCO

With Axial Stroke

Industrial

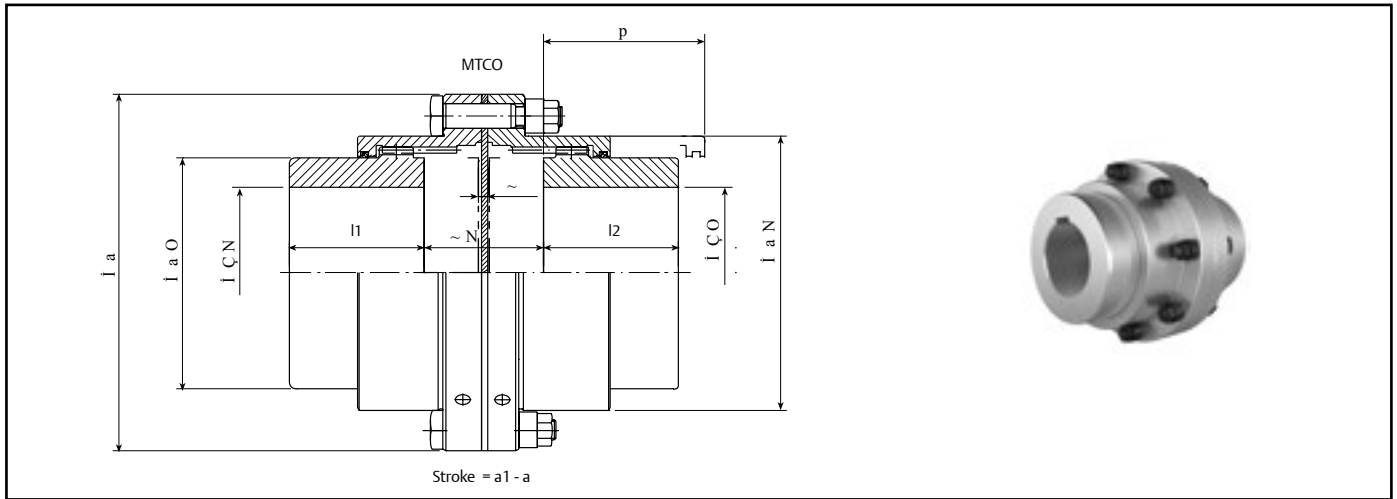

Designation example: **MTCO-132**

SIZE	TN NOMINAL (1)	TP MAX (1)	n MAX (8)	GENERAL DIMENSIONS								WEIGHT MAX. (5)	WEIGHT MIN. (6)	MOMENT OF INERTIA (5)	GREASE QTY. (7)
				D	D1	D2	d1-d2 (Min-Max) (2)(3)	l1-l2	a	a1	S(4)				
MTCO	Nm	Nm	rpm	D	D1	D2	d1-d2 (Min-Max) (2)(3)	l1-l2	a	a1	S(4)	kg	kg	J (kgm ²)	kg
52	1.780	3.600	8.600	111	82,5	69	14-52	43	6	26	57	4	3	0,005	0,03
62	2.790	5.520	7.000	141	104,5	85	17-62	50	6	36	64	8	6	0,016	0,06
78	5.600	11.100	5.800	171	127,5	107	20-78	62	6	46	76	14	10	0,040	0,09
98	8.500	17.400	4.700	210	156	133	26-98	76	8	58	92	26	18	0,11	0,14
112	14.000	28.200	4.200	234	181,5	152	30-112	90	8	88	108	39	26	0,20	0,29
132	23.000	45.600	3.600	274	210,5	178	35-132	105	11	92	125	58	42	0,45	0,42
156	35.100	69.600	3.200	312	248,5	209	70-156	120	11	102	140	91	61	0,88	0,60
174	44.400	88.000	2.900	337	274	234	85-174	135	13	122	162	115	77	1,33	1,04
190	68.500	139.600	2.600	380	308,5	254	95-190	150	13	146	180	165	115	2,48	1,73
210	84.600	167.600	2.400	405	334	279	110-210	175	14	168	205	211	142	3,59	2,48
233	151.000	304.000	2.200	444	365,5	305	120-233	190	14	180	218	260	167	5,00	3,46
275	205.500	407.000	2.000	506	424	355	130-275	220	16	212	252	411	252	10,39	5,31

From size 174 (included) the coupling is supplied by default with puller holes. If required, puller holes can also be made for smaller sizes.

Setscrews can be included upon request. Adapted hub length available upon request.

ATEX certifications are available. Please, contact JAURE to define the zone and category.



(1) The torque of the coupling does not include the connection transmission capacity.

(2) Minimum dimensions refer to already machined bore.

For A00 rough bore dimensions contact JAURE.

(3) Max. allowable bore for couplings with DIN 6885/1 keys.

For other types of keys or connections please contact JAURE.

(4) Clearance to align coupling hubs and replacement of sealing rings.

(5) Weight and moment of inertia are given for minimum bore.

(6) Weight is given for maximum bore.

(7) The amount of grease indicated in the catalogue is for guidance only.

For exact amount please refer to coupling instructions.

(8) n MAX speed for balanced couplings. For higher speeds contact JAURE.

Technical modifications reserved

MTES Disengaging

Industrial

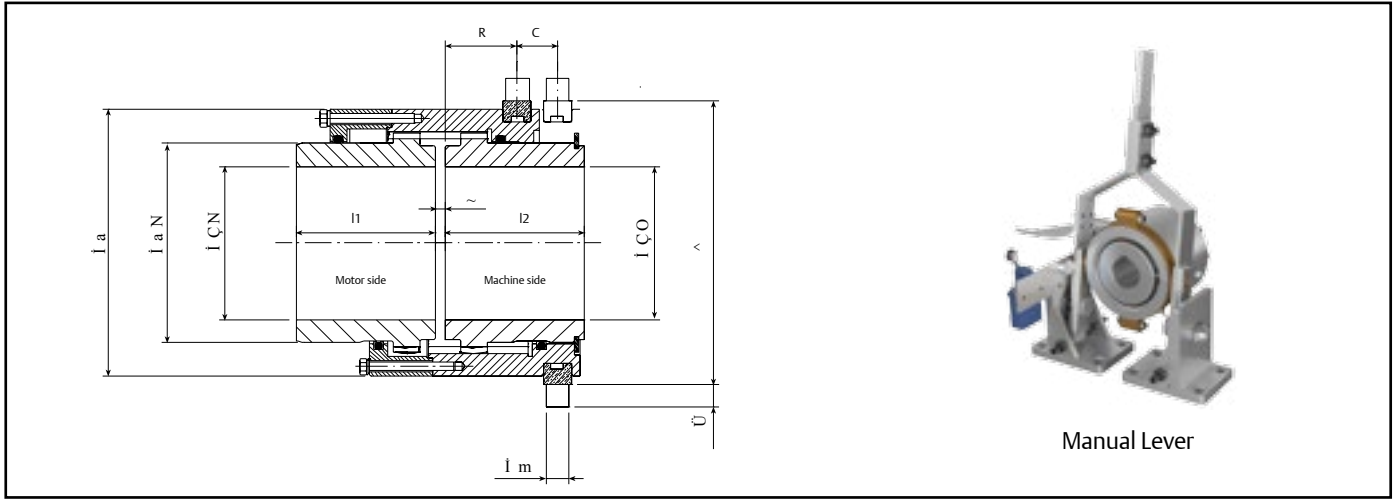

Designation example: MTES-125 / n = 150 (rpm)
Where "n" is the maximum speed

SIZE	TN NOMINAL (1)	TP MAX (1)	n MAX (8)	GENERAL DIMENSIONS										WEIGHT MAX. (5)	WEIGHT MIN. (6)	MOMENT OF INERTIA (5)	GREASE QTY. (7)
				D	D1	d1-d2 (Min-Max) (2)(3)	I1-I2	a	A	h	P	R	C(4)				
MTES	Nm	Nm	rpm	D	D1	d1-d2 (Min-Max) (2)(3)	I1-I2	a	A	h	P	R	C(4)	kg	kg	J (kgm ²)	kg
42	1.200	2.400	3.000	100	60	13-44	55	6	104	12	12	24	18	6	5	0,008	0,06
55	2.600	5.200	2.500	120	79	16-60	70	6	124	14	14	33	20	10	7	0,018	0,08
70	5.000	10.000	2.000	150	101	20-75	80	6	154	16	16	40	25	18	13	0,051	0,16
90	8.600	16.000	1.700	177	120	25-95	95	8	187	16	16	50	28	30	21	0,12	0,24
100	14.000	28.000	1.500	200	143	30-105	105	8	210	18	18	56	32	43	30	0,21	0,31
125	20.600	41.200	1.300	226	170	35-130	120	8	240	20	20	62	35	63	39	0,40	0,42
145	33.000	66.000	1.150	264	200	45-150	135	10	280	20	20	70	40	98	64	0,83	0,59
165	45.600	91.200	1.050	290	220	55-165	150	10	300	22	22	72	42	126	82	1,28	0,89
185	61.400	122.800	950	325	250	60-190	170	10	330	24	24	77	44	178	110	2,24	1,13
205	80.800	161.600	850	353	275	70-210	185	12	368	26	26	81	48	229	139	3,39	1,30
230	105.500	211.000	800	377	300	100-230	200	12	390	26	26	86	52	283	167	4,67	1,62
260	161.000	322.000	700	435	340	115-260	230	12	450	30	30	102	60	415	261	9,37	2,56

From size 185 (included) the coupling is supplied by default with puller holes. If required, puller holes can also be made for smaller sizes.
When engaging or disengaging the machine must be stopped and the shaft must be able to rotate free.

Pneumatic or hydraulic lever can be integrated on demand.
Setscrews can be included upon request.
Adapted hub length available upon request.

ATEX certifications are available. Please, contact JAURE to define the zone and category.



(1) The torque of the coupling does not include the connection transmission capacity.

(2) Minimum dimensions refer to already machined bore. For A00 rough bore dimensions contact Jaure.

(3) Max. allowable bore for couplings with DIN 6885/1 keys. For other types of keys or connections please contact JAURE.

(4) Stroke of the sleeve.

(5) Weight and moment of inertia are given for minimum bore.

(6) Weight is given for maximum bore.

(7) The amount of grease indicated in the catalogue is for guidance only. For exact amount please refer to coupling instructions.

(8) n MAX speed for balanced couplings. For higher speeds contact Jaure.

MTB With Shear Pins

Industrial

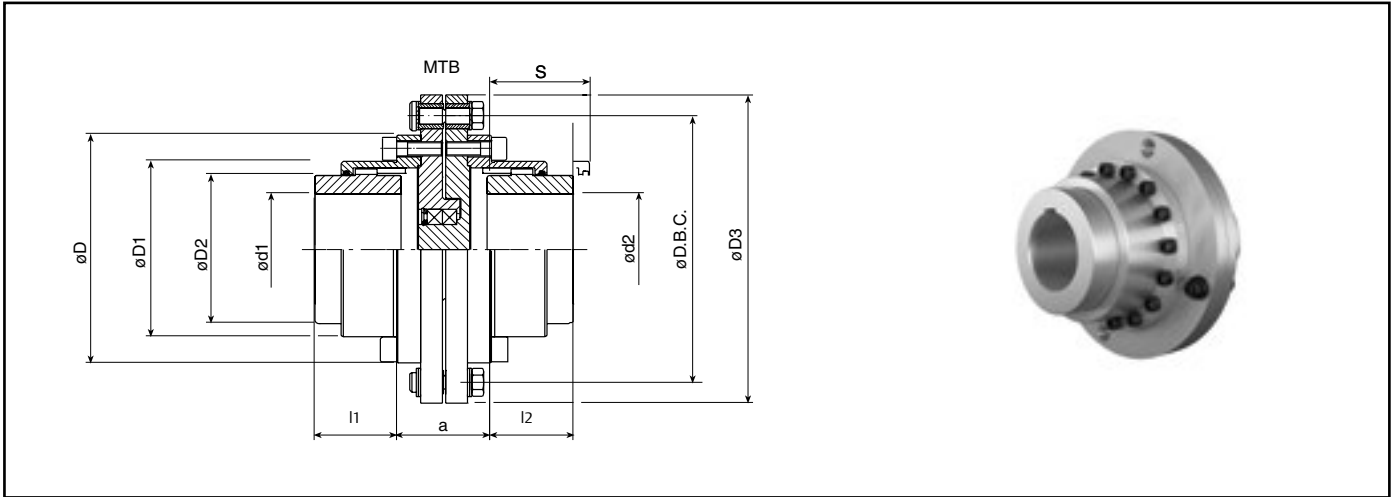

Designation example: MTB-132 / Tbr = 15000 (Nm)
Where Tbr is the designed breaking torque

SIZE	TN NOMINAL (1)	TP MAX (1)	n MAX (8)	GENERAL DIMENSIONS									WEIGHT MAX. (5)	WEIGHT MIN. (6)	MOMENT OF INERTIA (5)	GREASE QTY.(7)
MTB	Nm	Nm	rpm	D	D1	D2	D3	D.B.C.	d1-d2 (Min-Max) (2)(3)	l1-l2	a	S(4)	kg	kg	J (kgm ²)	kg
52	1.780	3.600	8.600	111	82,5	69	170	170	14-52	43	39	57	10	9	0,025	0,03
62	2.790	5.520	7.000	141	104,5	85	220	185	17-62	50	49	64	18	16	0,075	0,06
78	5.600	11.100	5.800	171	127,5	107	250	215	20-78	62	61	76	27	24	0,139	0,09
98	8.500	17.400	4.700	210	156	133	285	250	26-98	76	55	92	43	35	0,27	0,14
112	14.000	28.200	4.200	234	181,5	152	335	285	30-112	90	100	108	73	63	0,70	0,29
132	23.000	45.600	3.600	274	210,5	178	370	320	35-132	105	105	125	106	86	1,16	0,42
156	35.100	69.600	3.200	312	248,5	209	410	360	70-156	120	115	140	148	119	1,96	0,60
174	44.400	88.000	2.900	337	274	234	435	385	85-174	135	123	162	180	145	2,69	1,04
190	68.500	139.600	2.600	380	308,5	254	520	450	95-190	150	166	180	282	232	6,10	1,73
210	84.600	167.600	2.400	405	334	279	560	490	110-210	175	170	205	340	277	8,35	2,48
233	151.000	304.000	2.200	444	365,5	305	590	520	120-233	190	182	218	412	318	10,74	3,46
275	205.500	407.000	2.000	506	424	355	660	590	130-275	220	208	252	603	443	78,83	5,31

From size 174 (included) the coupling is supplied by default with puller holes. If required, puller holes can also be made for smaller sizes.

Setscrews can be included upon request.
Adapted hub length available upon request.

ATEX certifications are available. Please, contact JAURE to define the zone and category.



(1) The torque of the coupling does not include the connection transmission capacity.

(2) Minimum dimensions refer to already machined bore. For A00 rough bore dimensions contact Jaure.

(3) Max. allowable bore for couplings with DIN 6885/1 keys. For other types of keys or connections please contact JAURE.

(4) Clearance to align coupling hubs and replacement of sealing rings.

(5) Weight and moment of inertia are given for minimum bore.

(6) Weight is given for maximum bore.

(7) The amount of grease indicated in the catalogue is for guidance only.

For exact amount please refer to coupling instructions.

(8) n MAX speed for balanced couplings. For higher speeds contact Jaure.

Technical modifications reserved

MTNBR With Shear Pins

Industrial

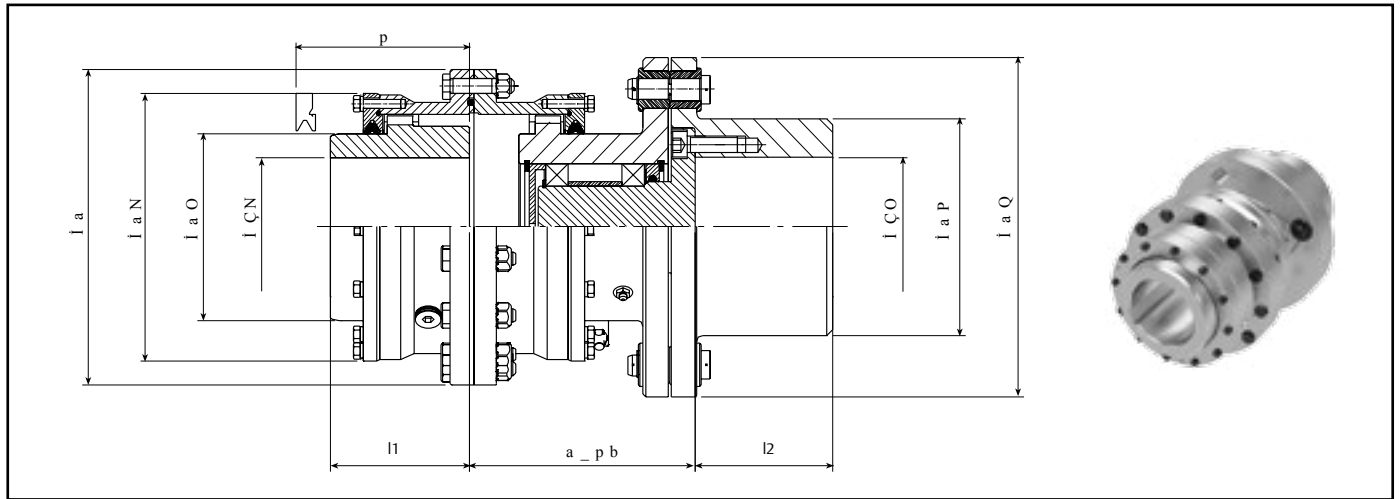

Designation example: MTNBR-125 / DBSE = 195 / Tbr = 15000 (Nm)

Where Tbr is the designed breaking torque

SIZE	TN NOMINAL (1)	TP MAX (1)	n MAX (8)	GENERAL DIMENSIONS									WEIGHT MAX. (5)	WEIGHT MIN. (6)	MOMENT OF INERTIA (5)	GREASE QTY.(7)
				D	D1	D2	D3	D4	d1-d2 (Min-Max) (2)(3)	l1-l2	DBSE	S(4)				
MTNBR	Nm	Nm	rpm	D	D1	D2	D3	D4	d1-d2 (Min-Max) (2)(3)	l1-l2	DBSE	S(4)	kg	kg	J (kgm ²)	kg
42	1.300	2.600	6.490	145	113	65	80	153	13-48	55	123±1	80	14	12	0,029	0,12
55	2.500	5.000	5.770	164	126	80	95	172	16-60	70	134±1	90	21	18	0,055	0,18
70	4.300	8.600	5.140	184	147	95	112	193	20-70	80	145±2	100	31	27	0,103	0,25
90	7.000	14.000	4.310	220	176	112	135	230	25-85	95	156±2	130	50	43	0,24	0,38
100	11.600	23.200	3.810	240	200	135	160	260	30-100	105	186±2	140	73	61	0,43	0,56
125	19.000	38.000	3.420	270	230	160	185	290	35-120	120	195±2	150	105	85	0,76	0,79
145	27.000	54.000	3.000	310	256	185	210	330	45-140	135	210±2	160	153	128	1,46	1,04
165	39.000	78.000	2.750	340	292	210	230	360	55-160	150	242±3	190	207	170	2,35	1,79
185	54.000	108.000	2.450	380	315	230	255	405	60-180	170	265±3	210	277	223	3,96	2,27
205	69.000	138.000	2.300	405	340	255	290	432	70-200	185	300±3	230	357	285	5,76	2,88
230	98.000	196.000	2.020	445	377	290	320	490	100-220	200	320±3	250	470	386	9,84	3,68
260	130.000	260.000	1.870	490	415	320	360	530	115-250	230	354±3	280	627	508	15,40	4,95

From size 185 (included) the coupling is supplied by default with puller holes. If required, puller holes can also be made for smaller sizes.

Setscrews can be included upon request.
Adapted hub length available upon request.

ATEX certifications are available. Please, contact JAURE to define the zone and category.



(1) The torque of the coupling does not include the connection transmission capacity.

(2) Minimum dimensions refer to already machined bore. For A00 rough bore dimensions contact Jaure.

(3) Max. allowable bore for couplings with DIN 6885/1 keys. For other types of keys or connections please contact JAURE.

(4) Clearance to align coupling hubs and replacement of sealing rings.

(5) Weight and moment of inertia are given for minimum bore.

(6) Weight is given for maximum bore.

(7) The amount of grease indicated in the catalogue is for guidance only. For exact amount please refer to coupling instructions.

(8) n MAX speed for balanced couplings. For higher speeds contact Jaure.

PLMT Rigid

Industrial

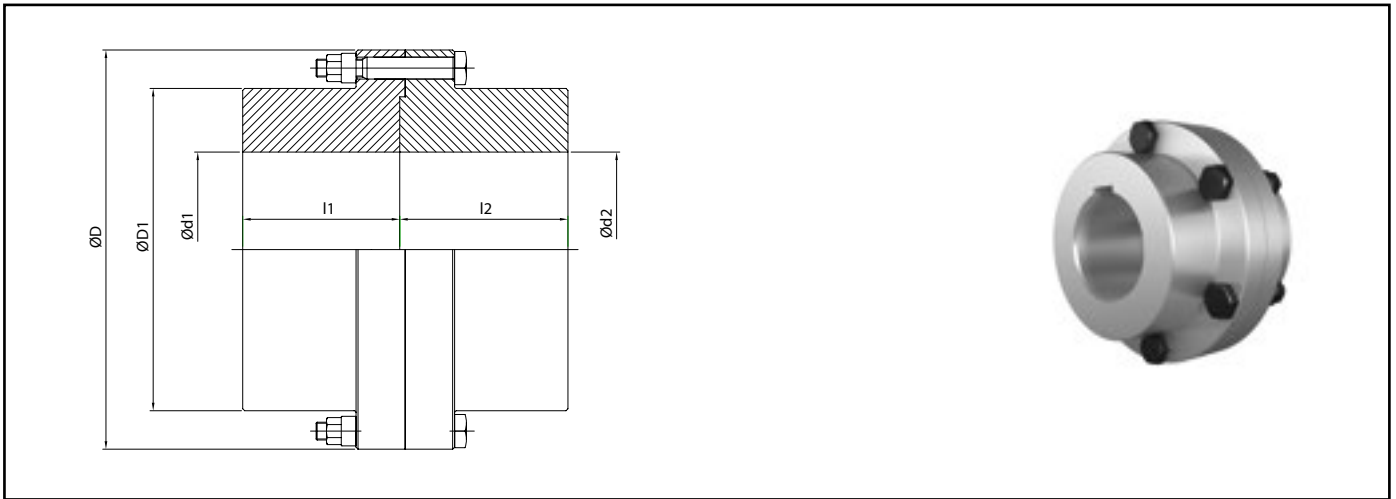

Designation example: **PLMT-78**

SIZE	TP MAX (1)(6)	GENERAL DIMENSIONS (mm)				WEIGHT MAX. (4)	WEIGHT MIN. (5)
PLMT	Nm	D	D1	d1-d2 (Min-Max) (2)(3)	l1-l2	kg	kg
52	3400	111	80	14-55	43	4,3	2,8
62	12600	141	100	17-70	50	8,3	5,4
78	20600	171	125	20-90	62	15	9
98	39100	210	148	26-105	76	26	16
112	59600	234	173	30-120	90	39	24
132	99400	274	204	35-145	105	64	39
156	115100	312	242	70-170	120	93	58
174	156900	337	268	85-190	135	123	75
190	193200	380	302	95-215	150	177	109
210	363200	405	327	110-230	175	232	144
233	394400	444	354	120-250	190	283	170
275	680600	506	410	130-290	220	442	260

From size 174 (included) the coupling is supplied by default with puller holes. If required, puller holes can also be made for smaller sizes.

Setscrews can be included upon request.
Adapted hub length available upon request.

ATEX certifications are available. Please, contact JAURE to define the zone and category.



(1) The torque of the coupling does not include the connection transmission capacity.

(2) Minimum dimensions refer to already machined bore.

For A00 rough bore dimensions contact Jaure.

(3) Max. allowable bore for couplings with DIN 6885/1 keys.

For other types of keys or connections please contact JAURE.

(4) Weight is given for minimum bore.

(5) Weight is given for maximum bore.

(6) Maximum torque transmitted through bolted joints.

(7) Body fitted bolts (Grade 10,9) are used.

(8) Special version available for flying drive applications with bending moments.

Technical modifications reserved

Marine designs

Jaure marine style gear couplings are operating for years in a variety of applications such as main propulsion & maneuvering of vessels, dredging including underwater use, fire fighting pumps, winches...

MARINE TYPE APPROVAL & MANUFACTURING SURVEY ARRANGEMENT

The Jaure MT gear couplings can be also delivered on demand with the 3.2 certificate of any Marine Classification Society.

Jaure is additionally awarded with the Manufacturing Survey Arrangement – MSA from DNV. The MSA certificate is our commitment to continuously improve the service and response time to our customers and remain competitive in the market place.



MT/MT-HD Basic Design

Marine

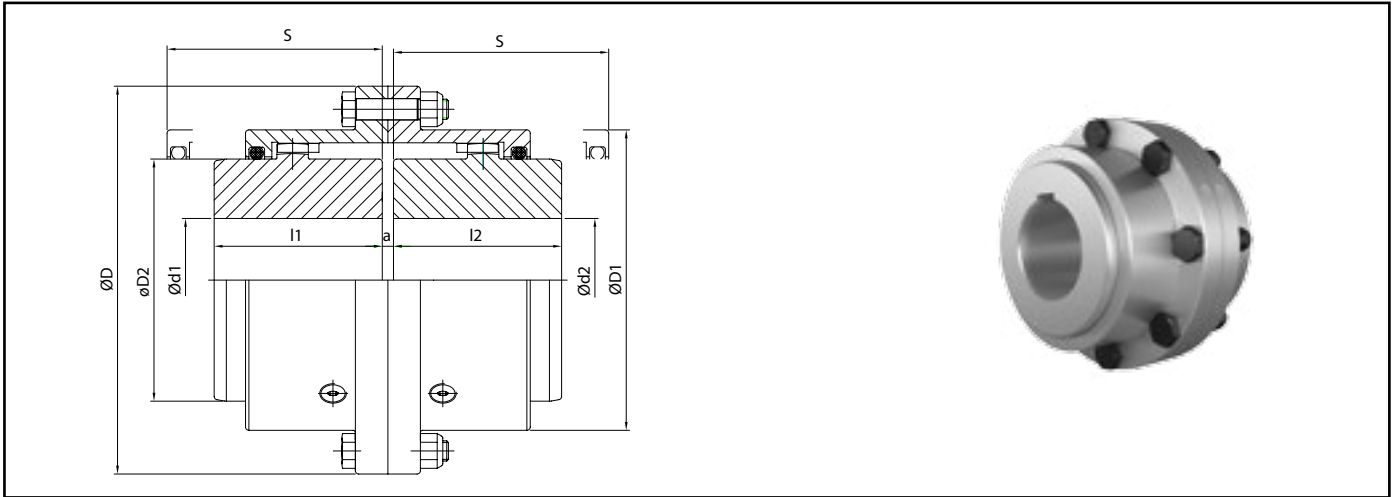

Designation example: **MT-125**

SIZE	MT		MT-HD		n MAX (8)	GENERAL DIMENSIONS							WEIGHT MAX (5)	WEIGHT MIN (6)	MOMENT OF INERTIA (5)	GREASE QTY. (7)
	TN NOMINAL (1)	TP MAX (1)	TN NOMINAL (1)	TP MAX (1)		D	D1	D2	d1-d2 (Min-Max) (2)(3)	l1-l2	a	S(4)				
MT MT-HD	Nm	Nm	Nm	Nm	rpm	D	D1	D2	d1-d2 (Min-Max) (2)(3)	l1-l2	a	S(4)	kg	kg	J (kgm ²)	kg
42	1.200	2.400	1.980	3.960	8.600	116	80	60	13-44	55	6	75	5	4	0,006	0,03
55	2.600	5.200	4.290	8.580	6.600	152	100	79	16-58	70	6	90	10	7	0,021	0,06
70	5.000	10.000	8.250	16.500	5.600	178	125	101	20-75	80	6	108	17	12	0,048	0,09
90	8.600	17.200	14.190	28.380	4.700	213	148	124	25-95	95	8	124	28	18	0,125	0,14
100	14.000	28.000	23.100	46.200	4.200	240	173	143	30-105	105	8	136	40	27	0,20	0,29
125	20.600	41.200	33.990	67.980	3.600	279	204	170	35-130	120	8	158	65	42	0,48	0,42
145	33.000	66.000	54.450	108.900	3.150	318	242	205	45-150	135	10	172	95	61	0,93	0,60
165	45.600	91.200	75.240	150.480	2.860	346	268	216	55-165	150	10	192	134	89	1,55	1,04
185	61.400	122.800	101.310	202.620	2.580	389	302	250	60-190	170	10	210	185	117	2,70	1,73
205	80.800	161.600	133.320	266.640	2.320	425	327	275	70-210	185	12	230	240	151	4,10	2,48
230	105.500	211.000	174.075	348.150	2.200	457	354	300	100-230	200	12	250	273	167	5,55	3,46
260	161.000	322.000	265.650	531.300	2.000	527	410	340	115-260	230	12	280	412	258	9,15	5,31

From size 185 (included) the coupling is supplied by default with puller holes. If required, puller holes can also be made for smaller sizes.

Setscrews can be included upon request.
Adapted hub length available upon request.

ATEX certifications are available. Please, contact JAURE to define the zone and category.



(1) The torque of the coupling does not include the connection transmission capacity.

(2) Minimum dimensions refer to already machined bore.

For A00 rough bore dimensions contact Jaure.

(3) Max. allowable bore for couplings with DIN 6885/1 keys.

For other types of keys or connections please contact JAURE.

(4) Clearance to align coupling hubs and replacement of sealing rings.

(5) Weight and moment of inertia are given for minimum bore.

(6) Weight is given for maximum bore.

(7) The amount of grease indicated in the catalogue is for guidance only.

For exact amount please refer to coupling instructions.

(8) n MAX speed for balanced couplings. For higher speeds contact Jaure.

Technical modifications reserved

MTG/MTG-HD

Basic Design

Marine

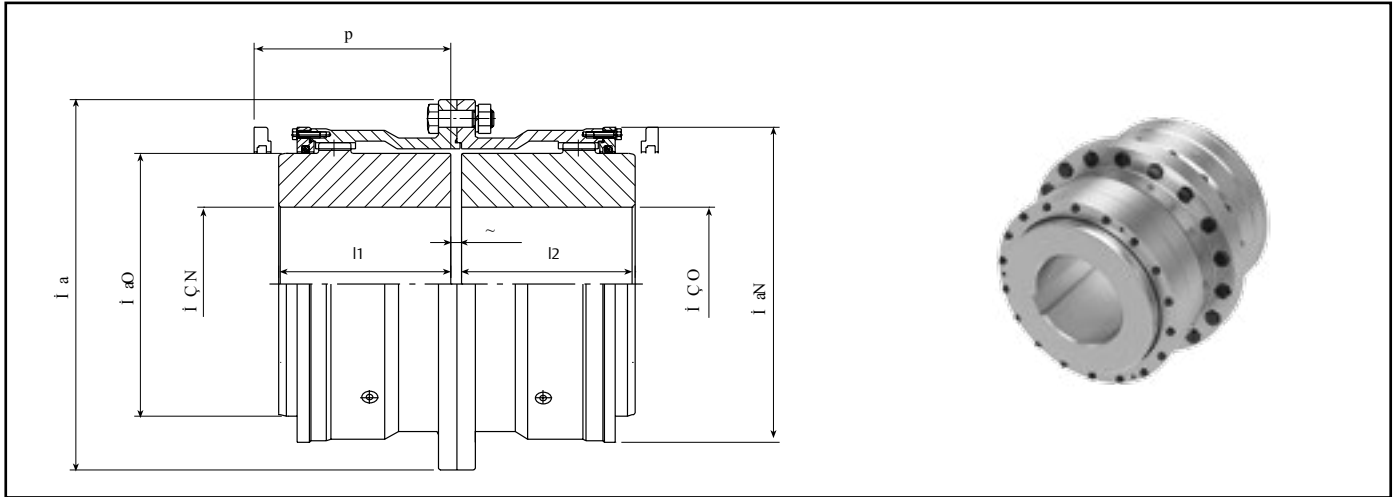

Designation example: **MTG-370**

SIZE	MTG		MTG-HD		n MAX (8)	GENERAL DIMENSIONS							WEIGHT MAX. (5)	WEIGHT MIN. (6)	MOMENT OF INERTIA (5)	GREASE QTY.(7)
	TN NOMINAL (1)	TP MAX (1)	TN NOMINAL (1)	TP MAX (1)		D	D1	D2	d1-d2 (min-max) (2)(3)	l1-l2	a	S(4)				
280	220.000	440.000	363.000	726.000	1.800	540	465	370	140-280	250	16	300	527	346	14,95	4
310	250.000	500.000	412.500	825.000	1.600	585	505	410	160-310	270	16	320	676	442	22,93	5,05
345	320.000	640.000	528.000	1.056.000	1.500	650	548	450	180-345	290	16	340	884	574	36,84	5,87
370	400.000	800.000	660.000	1.320.000	1.400	690	588	490	210-370	325	20	370	1.105	733	53,16	7,16
390	510.000	1.020.000	841.500	1.683.000	1.300	760	640	520	230-390	345	20	400	1.379	957	79,63	10,70
420	660.000	1.320.000	1.089.000	2.178.000	1.200	805	690	560	250-420	365	20	420	1.667	1.154	110	12
460	780.000	1.560.000	1.287.000	2.574.000	1.100	850	730	600	275-460	400	20	450	2.043	1.372	153	13,80
500	1.000.000	2.000.000	1.650.000	3.300.000	1.050	930	780	650	300-500	410	25	490	2.452	1.643	217	16,81
550	1.200.000	2.400.000	1.980.000	3.960.000	950	995	850	710	325-550	430	25	520	3.035	1.991	313	18,62
590	1.600.000	3.200.000	2.640.000	5.280.000	900	1.055	910	760	350-590	470	25	550	3.720	2.413	434	28,29
620	1.800.000	3.600.000	2.970.000	5.940.000	850	1.140	970	810	375-620	500	30	600	4.648	3.145	633	25,19
650	1.900.000	3.800.000	3.135.000	6.270.000	800	1.190	1.020	840	400-650	520	30	630	5.152	3.469	765	33,47
680	2.100.000	4.200.000	3.465.000	6.930.000	750	1.250	1.080	890	425-680	540	30	650	5.954	4.077	990	50,61
730	2.600.000	5.200.000	4.290.000	8.580.000	700	1.300	1.150	950	450-730	570	30	680	6.956	4.634	1.277	54,26
800	3.800.000	7.600.000	6.270.000	12.540.000	660	1.420	1.270	1.050	475-800	600	30	725	9.036	5.971	1.980	72,95
900	5.420.000	10.840.000	8.943.000	17.886.000	590	1.600	1.430	1.180	500-900	670	35	800	13.330	8.670	3.663	91,90
1.000	7.250.000	14.500.000	11.962.500	23.925.000	550	1.740	1.570	1.320	525-1000	740	35	890	17.975	11.130	5.766	112,98
1.100	8.650.000	17.300.000	14.272.500	28.545.000	500	1.880	1.710	1.450	550-1100	800	35	980	23.150	13.930	8.683	135
1.200	10.750.000	21.500.000	17.737.500	35.475.000	480	1.990	1.830	1.580	575-1200	850	35	1.030	28.605	16.680	12.239	162,50

► The coupling is supplied by default with puller holes. If required, puller holes can also be made for smaller sizes.

► Adapted hub length available upon request.

► ATEX certifications are available. Please, contact JAURE to define the zone and category.



► Setscrews can be included upon request.

(1) The torque of the coupling does not include the connection transmission capacity.

(2) Minimum dimensions refer to already machined bore.

For A00 rough bore dimensions contact Jaure.

(3) Max. allowable bore for couplings with DIN 6885/1 keys.

For other types of keys or connections please contact JAURE.

(4) Clearance to align coupling hubs and replacement of sealing rings.

(5) Weight and moment of inertia are given for minimum bore.

(6) Weight is given for maximum bore.

(7) The amount of grease indicated in the catalogue is for guidance only.

For exact amount please refer to coupling instructions.

(8) n MAX speed for balanced couplings. For higher speeds contact Jaure.

Technical modifications reserved

MTD/MTD-HD With Floating Shaft

Marine

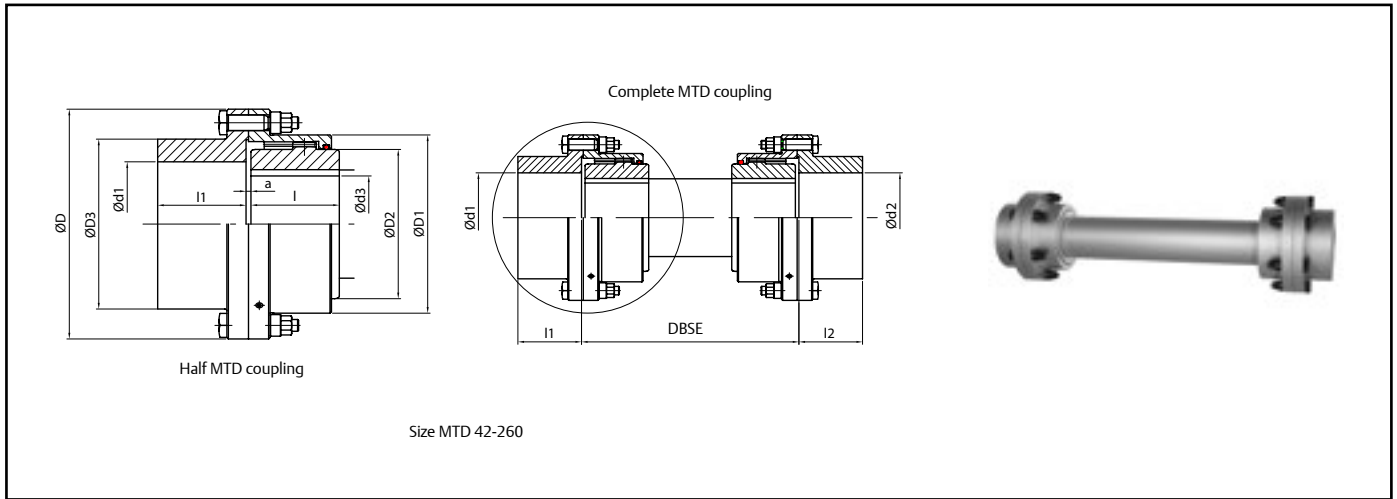

Designation example: **MTD-125 / DBSE = 1200 (mm) / n = 1500 rpm**

SIZE	MTD		MTD-HD		n MAX (8)	GENERAL DIMENSIONS							WEIGHT MAX (5)	WEIGHT MAX (6)	MOMENT OF INERTIA (5)	GREASE QTY. (7)	
	TN NOMINAL (1)	TP MAX (1)	TN NOMINAL (1)	TP MAX (1)		D	D1	D2	d1-d2 (Min-Max) (2)(3)	D3	d3 (Min-Max) (2)(3)	l1-l2					a
MTD MTD-HD	Nm	Nm	Nm	Nm	rpm								kg.	kg.	J (kgm ²)	kg.	
42	1.200	2.400	1.980	3.960	For max. Allowable speed check fig n°8 at page 14	116	80	60	13-55	80	13-44	55	7	20,7	20	0,014	0,03
55	2.600	5.200	4.290	8.580		152	100	79	16-70	100	16-58	70	7	38	35	0,050	0,06
70	5.000	10.000	8.250	16.500		178	125	101	20-90	125	20-75	80	7	61	56	0,116	0,09
90	8.000	16.000	13.200	26.400		213	148	124	25-105	148	25-95	95	8	100	90	0,289	0,14
100	14.000	28.000	23.100	46.200		240	173	143	30-120	173	30-105	105	8	149	136	0,49	0,29
125	20.600	41.200	33.990	67.980		279	204	170	35-145	204	35-130	120	8	211	188	1,14	0,42
145	33.000	66.000	54.450	108.900		318	242	205	45-170	242	45-150	135	10	300	266	2,19	0,60
165	45.600	91.200	75.240	150.480		346	268	216	55-190	268	55-165	150	10	397	352	3,54	1,04
185	61.400	122.800	101.310	202.620		389	302	250	60-215	302	60-190	170	10	539	471	6,30	1,73
205	80.800	161.600	133.320	266.640		425	327	275	70-230	327	70-210	185	11	673	584	9,42	2,48
230	105.500	211.000	174.075	348.150		457	354	300	100-250	354	100-230	200	11	786	680	12,74	3,46
260	161.000	322.000	265.650	531.300		527	410	340	115-290	410	115-260	230	12	1115	961	23,13	5,31

- From size 185 (included) the coupling is supplied by default with puller holes. If required, puller holes can also be made for smaller sizes.
- Distance to be specified by the customer. DBSE is distance between shafts ends, not between flanges.

- Setscrews can be included upon request.
- Adapted hub length available upon request.

- ATEX certifications are available. Please, contact JAURE to define the zone and category.



(1) The torque of the coupling does not include the connection transmission capacity.

(2) Minimum dimensions refer to already machined bore.

For A00 rough bore dimensions contact Jaure.

(3) Max. allowable bore for couplings with DIN 6885/1 keys.

For other types of keys or connections please contact JAURE.

(4) Clearance to align coupling hubs and replacement of sealing rings

(5) Weight and moment of inertia are given for minimum bore.

(6) Weight is given for maximum bore and 1m DBSE.

(7) The amount of grease indicated in the catalogue is for guidance only.

For exact amount please refer to coupling instructions.

(8) n MAX speed for balanced couplings. For higher speeds contact Jaure.

Technical modifications reserved

MTGD / MTGD-HD With Intermediate Floating Shaft

Marine

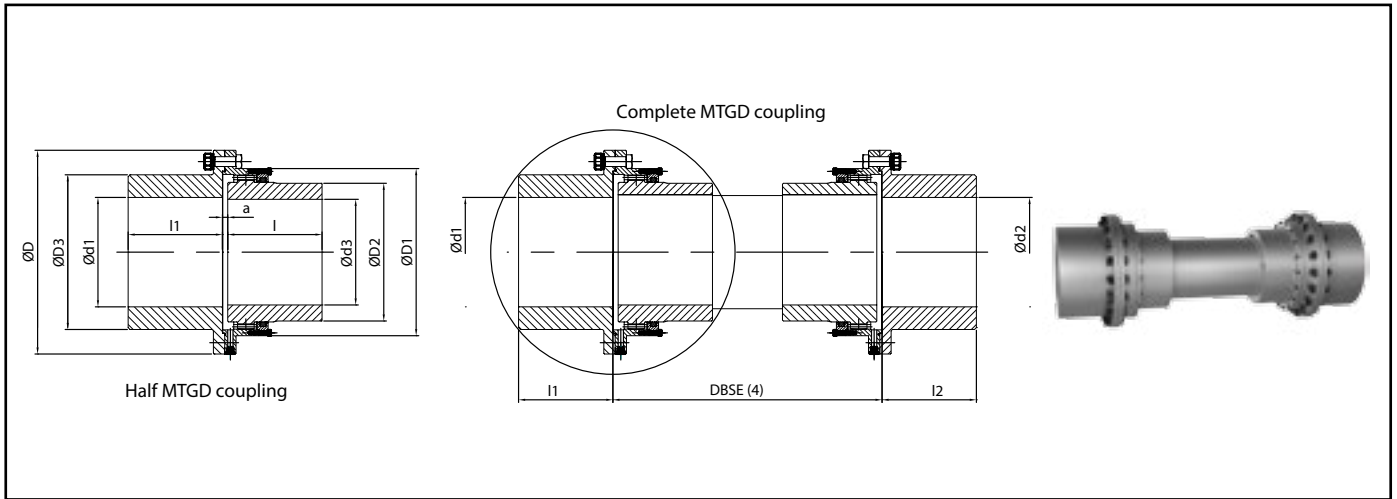

Designation example: **MTGD-370 / DBSE=1200 (mm) / n = 750 rpm**

SIZE	MTGD		MTGD-HD		n MAX (8)	GENERAL DIMENSIONS								WEIGHT MAX. (5)	WEIGHT PER 100MM SHAFT	WEIGHT MIN. (6)	MOMENT OF INERTIA (5)	MOMENT OF INERTIA PER 100MM SHAFT	GREASE QTY. (7)
	TN NOMINAL (1)	TP MAX (1)	TN NOMINAL (1)	TP MAX (1)		D	D1	D2	D3	d1-d2 (Min-Max (2)(3))	d3 (Min-Max (2)(3))	l1-l2	a						
MTGD MTGD- HD	Nm	Nm	Nm	Nm	rpm														
280	220.000	440.000	363.000	726.000	For max. allowable speed contact JAURE	540	465	370	410	140-290	140-280	250	16	1.980	55,5	1.781	33	0,624	1,73
310	250.000	500.000	412.500	825.000		585	505	410	460	160-350	160-310	270	16	2.470	67,1	2.147	51	0,914	2,19
345	320.000	640.000	528.000	1.056.000		650	548	450	500	180-380	180-345	290	16	3.072	82,1	2.671	79	1,368	2,52
370	400.000	800.000	660.000	1.320.000		690	588	490	540	210-410	210-370	325	20	3.632	93,8	3.135	109	1,78	3,03
390	510.000	1.020.000	841.500	1.683.000		760	640	520	590	230-450	230-390	345	20	4.258	103,6	3.621	155	2,18	3,64
420	660.000	1.320.000	1.089.000	2.178.000		805	690	560	630	250-480	250-420	365	20	5.021	122,1	4.266	210	3,02	4,52
460	780.000	1.560.000	1.287.000	2.574.000		850	730	600	680	275-520	275-460	400	20	6.056	145,0	5.096	296	4,26	4,83
500	1.000.000	2.000.000	1.650.000	3.300.000		930	780	650	730	300-560	300-500	410	25	7.161	169,9	6.031	418	5,85	7,05
550	1.200.000	2.400.000	1.980.000	3.960.000		995	850	710	790	325-600	325-550	430	25	8.646	203,8	7.297	592	8,42	7,38
590	1.600.000	3.200.000	2.640.000	5.280.000		1.055	910	760	850	350-650	350-590	470	25	10.316	237,0	8.577	822	11,39	9,58
620	1.800.000	3.600.000	2.970.000	5.940.000		1.140	970	810	890	375-680	375-620	500	30	11.848	260,5	9.864	1.096	13,76	11,95
650	1.900.000	3.800.000	3.135.000	6.270.000		1.190	1.020	840	930	400-710	400-650	520	30	13.094	285,1	10.887	1.331	16,48	14,30
680	2.100.000	4.200.000	3.465.000	6.930.000		1.250	1.080	890	1.010	425-770	425-680	540	30	15.177	319,6	12.432	1.777	20,71	20,26
730	2.600.000	5.200.000	4.290.000	8.580.000		1.300	1.150	950	1.060	450-810	450-730	570	30	17.501	375,1	14.313	2.276	28,53	21,56
800	3.800.000	7.600.000	6.270.000	12.540.000		1.420	1.270	1.050	1.170	475-900	475-800	600	30	21.610	435,0	17.286	3.410	38,37	26,62
900	5.420.000	10.840.000	8.943.000	17.886.000		1.600	1.430	1.180	1.330	500-900	500-900	670	35	29.654	556,4	23.292	6.125	62,77	35,18
1.000	7.250.000	14.500.000	11.962.500	23.925.000		1.740	1.570	1.320	1.470	525-1000	525-1000	740	35	29.506	692,7	20.575	7.999	97,30	43,69
1.100	8.650.000	17.300.000	14.272.500	28.545.000		1.880	1.710	1.450	1.610	550-1100	550-1100	800	35	36.272	829,6	24.332	10.894	140	55,48
1.200	10.750.000	21.500.000	17.737.500	35.475.000		1.990	1.830	1.580	1.730	575-1200	575-1200	850	35	43.404	978,8	28.607	16.590	194	54,62

► The coupling is supplied by default with puller holes. If required, puller holes can also be made for smaller sizes.

► Setscrews can be included upon request.
► Adapted hub length available upon request.

► ATEX certifications are available. Please, contact JAURE to define the zone and category.



(1) The torque of the coupling does not include the connection transmission capacity.

(2) Minimum dimensions refer to already machined bore.

For A00 rough bore dimensions contact JAURE.

(3) Max. allowable bore for couplings with DIN 6885/1 keys.

For other types of keys or connections please contact JAURE.

(4) Distance to be specified by the customer.

DBSE is distance between shafts ends, not between flanges.

(5) Weight, moment of inertia and torsional stiffness are given for minimum bore and 2.5 m DBSE for full MTGD coupling.

(6) Weight is given for maximum bore and 2.5 m DBSE for full MTGD coupling.

(7) The amount of grease indicated in the catalogue is for guidance only.

For exact amount please refer to coupling instructions.

(8) n MAX speed for balanced couplings. For higher speeds contact JAURE.

Technical modifications reserved

MTX/MTX-HD With Spacer

Marine

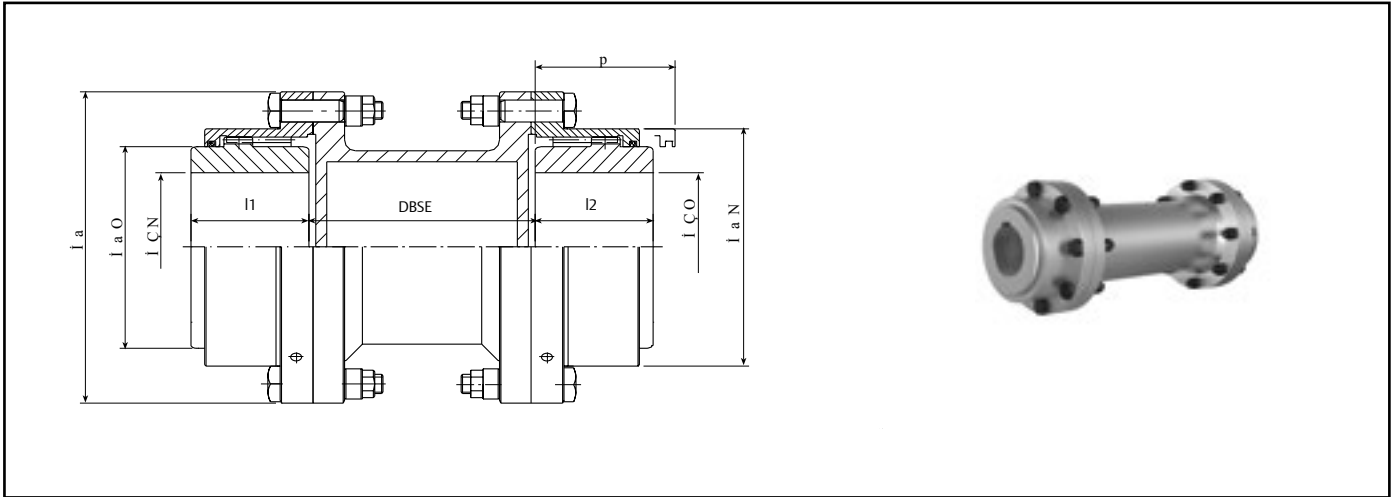

Designation example: **MTX-125**

SIZE	MTX		MTX-HD		n MAX (8)	GENERAL DIMENSIONS						WEIGHT MAX (5)	WEIGHT MIN (6)	MOMENT OF INERTIA (5)	GREASE QTY. (7)
	TN NOMINAL (1)	TP MAX (1)	TN NOMINAL (1)	TP MAX (1)		D	D1	D2	d1-d2 (Min-Max) (2)(3)	l1-l2	S(4)				
MTX MTX-HD	Nm	Nm	Nm	Nm	rpm							kg	kg	J(kgm ²)	kg
42	1.200	2.400	1.980	3.960	For max. Allowable speed check fig n°7 at page 14	116	80	60	13-44	55	75	15	14	0,018	0,03
55	2.600	5.200	4.290	8.580		152	100	79	16-58	70	90	25	22	0,052	0,06
70	5.000	10.000	8.250	16.500		178	125	101	20-75	80	108	39	34	0,107	0,09
90	8.600	17.200	14.190	28.380		213	148	124	25-95	95	124	62	52	0,285	0,14
100	14.000	28.000	23.100	46.200		240	173	143	30-105	105	136	81	68	0,05	0,29
125	20.600	41.200	33.990	67.980		279	204	170	35-130	120	158	120	97	0,99	0,42
145	33.000	66.000	54.450	108.900		318	242	205	45-150	135	172	173	139	1,77	0,60
165	45.600	91.200	75.240	150.480		346	268	216	55-165	150	192	235	190	2,84	1,04
185	61.400	122.800	101.310	202.620		389	302	250	60-190	170	210	344	276	5,48	1,73
205	80.800	161.600	133.320	266.640		425	327	275	70-210	185	230	388	299	6,99	2,48
230	105.500	211.000	174.075	348.150		457	354	300	100-230	200	250	446	340	9,87	3,46
260	161.000	322.000	265.650	531.300		527	410	340	115-260	230	280	660	506	17,14	5,31

- From size 185 (included) the coupling is supplied by default with puller holes. If required, puller holes can also be made for smaller sizes.
- Distance to be specified by the customer. DBSE is distance between shafts ends, not between flanges.

- Setscrews can be included upon request.
- Adapted hub length available upon request.

- ATEX certifications are available. Please, contact JAURE to define the zone and category.



(1) The torque of the coupling does not include the connection transmission capacity.

(2) Minimum dimensions refer to already machined bore.

For A00 rough bore dimensions contact Jaure.

(3) Max. allowable bore for couplings with DIN 6885/1 keys.

For other types of keys or connections please contact JAURE.

(4) Clearance to align coupling hubs and replacement of sealing rings

(5) Weight and moment of inertia are given for minimum bore and 1m DBSE.

(6) Weight is given for maximum bore and 1m DBSE.

(7) The amount of grease indicated in the catalogue is for guidance only.

For exact amount please refer to coupling instructions.

(8) n MAX speed for balanced couplings. For higher speeds contact Jaure.

Technical modifications reserved

MTGX/MTGX-HD With Spacer

Marine

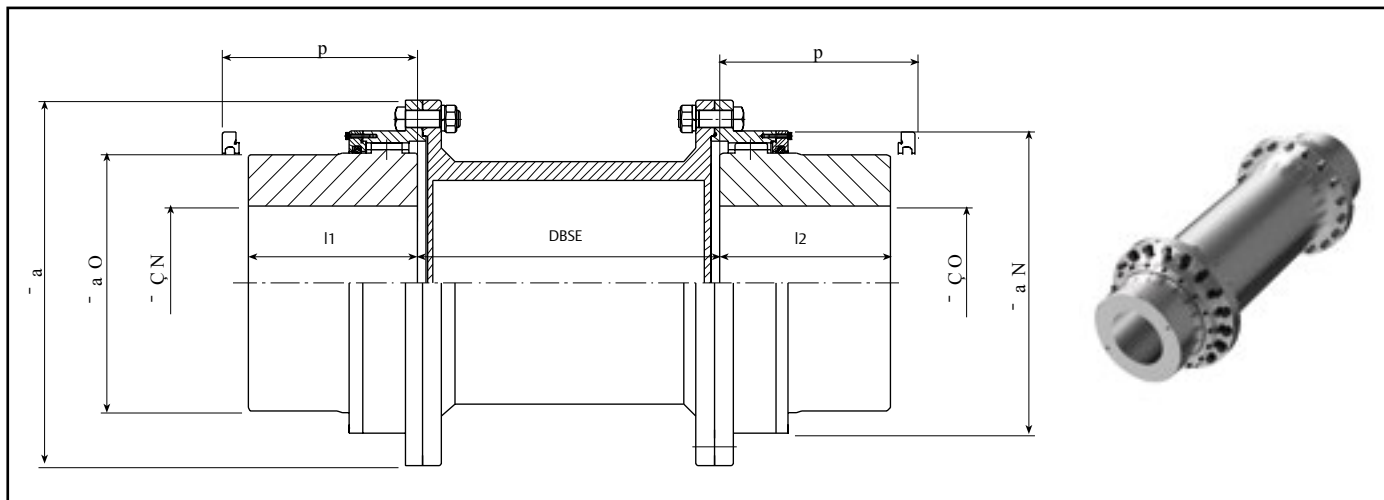

Designation example: **MTGX-370 / DBSE= 1000 (mm) / n= 750rpm**

SIZE	MTGX		MTGX-HD		n MAX (8)	GENERAL DIMENSIONS						WEIGHT MAX. (5)	WEIGHT PER 100MM SPACER	WEIGHT MIN. (6)	MOMENT OF INERTIA	MOMENT OF INERTIA PER 100MM SPACER	GREASE QTY. (7)
	TN NOMINAL (1)	TP MAX (1)	TN NOMINAL (1)	TP MAX (1)		D	D1	D2	d1-d2 (min-max) (2)(3)	l1-l2	S(4)						
MTGX MTGX- HD	Nm	Nm	Nm	Nm	rpm						kg	kg	kg	J (kgm ²)	J (kgm ²)	kg	
280	220.000	440.000	363.000	726.000	For max. allowable speed consult JAURE.	540	443	370	140-280	250	300	765	25,0	584	23	0,72	1,73
310	250.000	500.000	412.500	825.000		585	488	410	160-310	270	320	935	27,8	700	33	0,99	2,19
345	320.000	640.000	528.000	1.056.000		650	531	450	180-345	290	340	1.178	31,6	868	53	1,45	2,52
370	400.000	800.000	660.000	1.320.000		690	571	490	210-370	325	370	1.450	36,4	1.078	71	1,64	3,03
390	510.000	1.020.000	841.500	1.683.000		760	627	520	230-390	345	400	1.816	46,2	1.394	108	2,55	3,64
420	660.000	1.320.000	1.089.000	2.178.000		805	673	560	250-420	365	420	2.072	46,4	1.559	142	3,19	4,52
460	780.000	1.560.000	1.287.000	2.574.000		850	717	600	275-460	400	450	2.486	56,2	1.815	193	4,59	4,83
500	1.000.000	2.000.000	1.650.000	3.300.000		930	769	650	300-500	410	490	2.997	61,2	2.188	279	5,90	7,05
550	1.200.000	2.400.000	1.980.000	3.960.000		995	834	710	325-550	430	520	3.563	65,0	2.519	389	8,04	7,38
590	1.600.000	3.200.000	2.640.000	5.280.000		1.055	894	760	350-590	470	550	4.370	81,6	3.062	533	11,06	9,58
620	1.800.000	3.600.000	2.970.000	5.940.000		1.140	944	810	375-620	500	600	5.475	92,5	3.972	781	13,06	11,95
650	1.900.000	3.800.000	3.135.000	6.270.000		1.190	984	840	400-650	520	630	5.940	89,3	4.257	929	14,52	14,30
680	2.100.000	4.200.000	3.465.000	6.930.000		1.250	1.059	890	425-680	540	650	6.810	94,9	4.934	1.188	17,39	20,26
730	2.600.000	5.200.000	4.290.000	8.580.000		1.300	1.109	950	450-730	570	680	7.758	106	5.436	1.493	24,22	21,56
800	3.800.000	7.600.000	6.270.000	12.540.000		1.420	1.224	1.050	475-800	600	725	9.990	141,7	6.924	2.270	38,80	26,62
900	5.420.000	10.840.000	8.943.000	17.886.000		1.600	1.384	1.180	500-900	670	800	14.308	176,1	9.682	4.084	62,50	35,18
1.000	7.250.000	14.500.000	11.962.500	23.925.000		1.740	1.524	1.320	525-1000	740	890	18.746	198,3	12.136	6.265	89,19	43,69
1.100	8.650.000	17.300.000	14.272.500	28.545.000		1.880	1.664	1.450	550-1100	800	980	23.940	230	14.988	9.238	118,66	55,48
1.200	10.750.000	21.500.000	17.737.500	35.475.000		1.990	1.784	1.580	575-1200	850	1.030	29.217	254,1	17.590	12.806	159,84	54,62

► The coupling is supplied by default with puller holes. If required, puller holes can also be made for smaller sizes.
► Distance to be specified by the customer. DBSE is distance between shafts ends, not between flanges.

► Setscrews can be included upon request.
► Adapted hub length available upon request.

► ATEX certifications are available. Please, contact JAURE to define the zone and category.



(1) The torque of the coupling does not include the connection transmission capacity.

(2) Minimum dimensions refer to already machined bore.

For A00 rough bore dimensions contact Jaure.

(3) Max. allowable bore for couplings with DIN 6885/1 keys.

For other types of keys or connections please contact JAURE.

(4) Clearance to align coupling hubs and replacement of sealing rings.

(5) Weight, moment of inertia and torsional stiffness are given for minimum bore and 1m DBSE.

(6) Weight is given for maximum bore and 1m DBSE.

(7) The amount of grease indicated in the catalogue is for guidance only.

For exact amount please refer to coupling instructions.

(8) n MAX speed for balanced couplings. For higher speeds contact Jaure.

Technical modifications reserved

MTX-LI

Oil Lubricated With Spacer

Marine

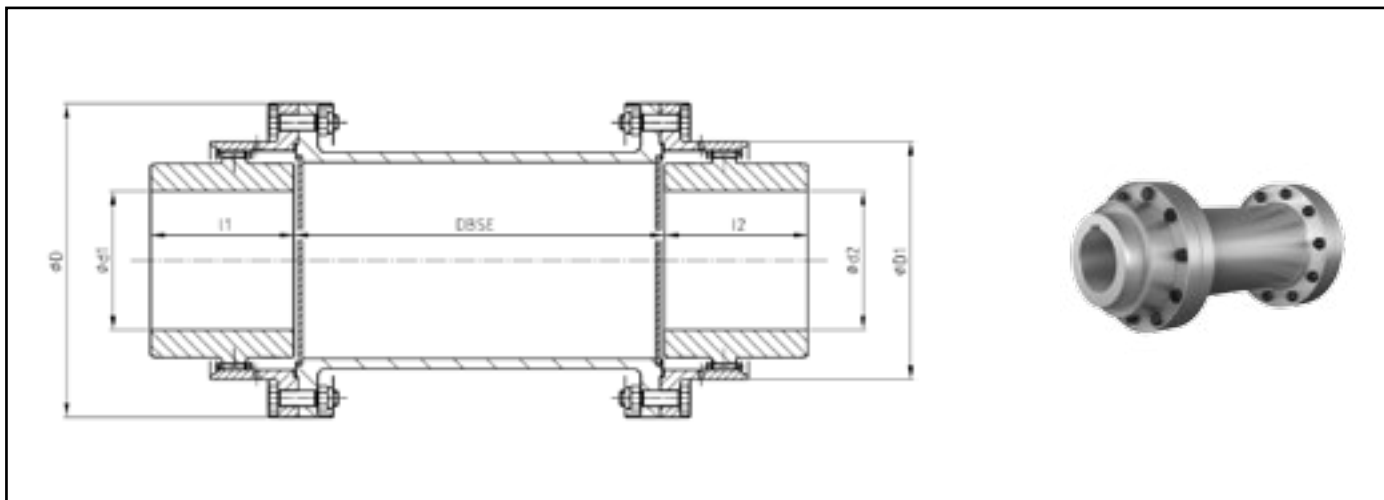

Designation example: **MTX-LI-125 DBSE=360 / n: 1500rpm**

SIZE	TN NOMINAL (1)	TP MAX (1)	n MAX (6)	GENERAL DIMENSIONS				WEIGHT MAX. (4)	WEIGHT MIN. (5)	MOMENT OF INERTIA (4)
MTX-LI	Nm	Nm	rpm	D	D1	d1-d2 (min-max) (2)(3)	l1-l2	kg.	kg.	J (kg m ²)
100	14.000	28.000	For max. allowable speed, see Fig. N° 7 on page 14	246	175	30-105	105	92	78	0,58
125	20.600	41.200		287	204	35-130	120	128	104	1,19
145	33.000	66.000		325	242	45-150	135	165	131	1,78
165	45.600	91.200		351	268	55-165	150	225	180	2,86
185	61.400	122.800		395	302	60-190	170	303	235	5,16
205	80.800	161.600		420	327	70-210	185	393	303	7,31
230	105.500	211.000		447	354	100-230	200	483	377	12,14
260	161.000	322.000		520	410	115-260	230	680	526	19,31
280	220.000	440.000		552	442	135-280	250	861	676	26,48
310	250.000	500.000		596	486	155-310	270	1054	814	38,84
345	320.000	640.000		662	532	175-345	290	1220	904	56,12

From size 185 (included) the coupling is supplied by default with puller holes. If required, puller holes can also be made for smaller sizes.

Setscrews can be included upon request.
Adapted hub length available upon request.

ATEX certifications are available. Please, contact JAURE to define the zone and category.



(1) The torque of the coupling does not include the connection transmission capacity.

(2) Minimum dimensions refer to already machined bore. For A00 rough bore dimensions contact Jaure.

(3) Max. allowable bore for couplings with DIN 6885/1 keys. For other types of keys or connections please consult JAURE.

(4) Weight and moment of inertia are given for minimum bore d1-d2 and 1m DBSE.

(5) Weight is given for maximum bore d1-d2 and 1m DBSE.

(6) n MAX speed for balanced couplings. For higher speeds contact Jaure.

Technical modifications reserved

MTD-LE Lubricated With Floating Shaft

Marine

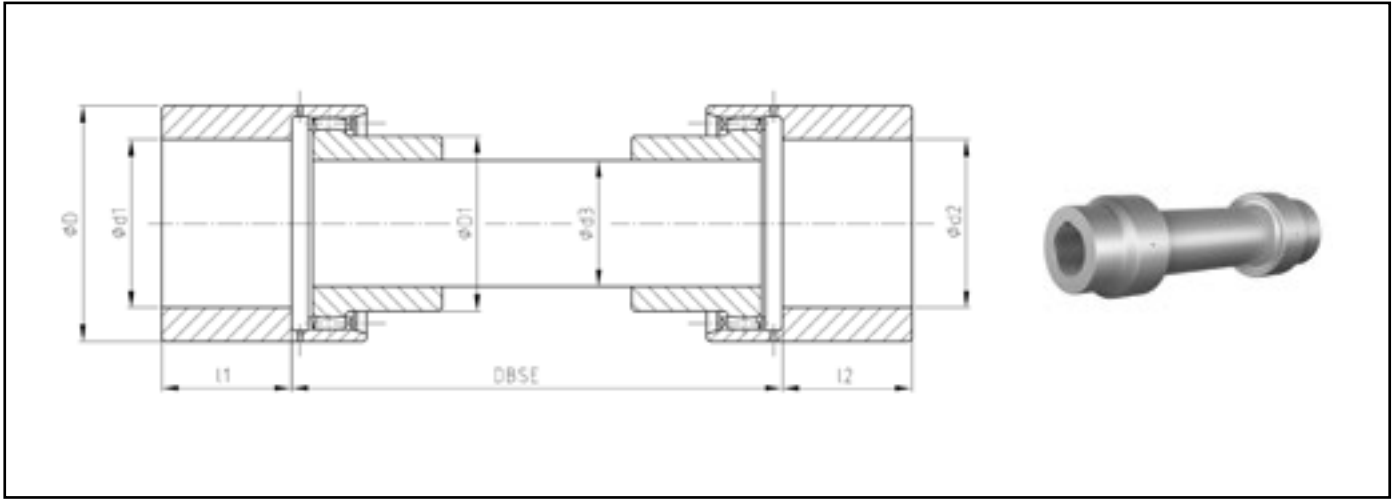

Designation example: MTD-LE-125 DBSE=360 / n: 1500rpm

SIZE	TN NOMINAL (1)	TP MAX (1)	n MAX (6)	GENERAL DIMENSIONS					WEIGHT MAX. (4)	WEIGHT MIN. (5)	MOMENT OF INERTIA (4)
				D	D1	d1-d2 (min-max) (2)(3)	d3 (min-max) (2)	l1-l2			
MTD-LE	Nm	Nm	rpm						kg.	kg.	J (kg m ²)
100	14.000	28.000	For max. allowable speed, see Fig. N° 8 on page 14	178	143	30-135	30-105	105	118	96	0,32
125	20.600	41.200		209	170	35-160	35-130	120	182	146	0,68
145	33.000	66.000		247	205	45-185	45-150	135	266	213	1,44
165	45.600	91.200		273	216	55-205	55-165	150	331	259	2,20
185	61.400	122.800		307	250	60-230	60-190	170	459	356	4,01
205	80.800	161.600		332	275	70-250	70-210	185	572	441	6,03
230	105.500	211.000		359	300	100-270	100-230	200	697	542	8,86
260	161.000	322.000		415	340	115-315	115-260	230	986	742	17,04
280	220.000	440.000		470	370	135-355	135-280	250	1267	935	28,22
310	250.000	500.000		491	410	155-375	155-310	270	1529	1141	38,84
345	320.000	640.000		537	450	175-410	175-345	290	1914	1422	59,29

From size 185 (included) the coupling is supplied by default with puller holes. If required, puller holes can also be made for smaller sizes.

Setscrews can be included upon request.
Adapted hub length available upon request.

ATEX certifications are available. Please, contact JAURE to define the zone and category.



(1) The torque of the coupling does not include the connection transmission capacity.

(2) Minimum dimensions refer to already machined bore.

For A00 rough bore dimensions contact Jaure.

(3) Max. allowable bore for couplings with DIN 6885/1 keys.

For other types of keys or connections please contact JAURE.

(4) Weight and moment of inertia are given for minimum bore d1-d2; maximum bore d3 and 1m DBSE.

(5) Weight is given for maximum bore d1-d2; maximum bore d3 and 1m DBSE.

(6) n MAX speed for balanced couplings. For higher speeds contact Jaure.

MTV

For Vertical Installation

Marine

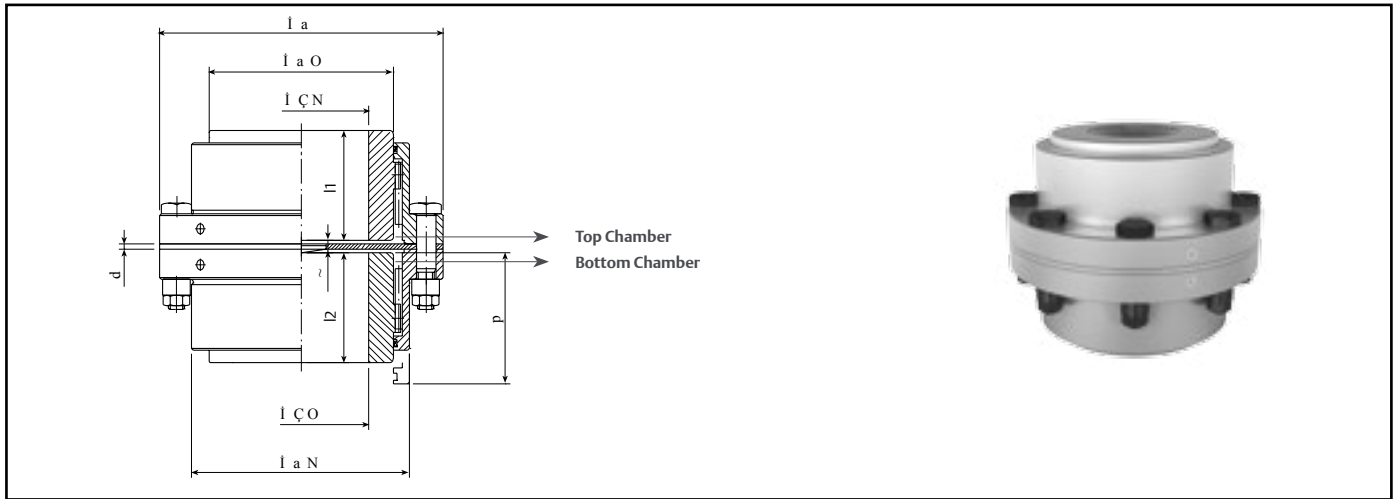

Designation example: MTV-42

SIZE	TN NOMINAL (1)	TP MAX (1)	n MAX (8)	GENERAL DIMENSIONS									WEIGHT MAX (5)	WEIGHT MIN (6)	MOMENT OF INERTIA (5)	GREASE QTY. TOP CHAMBER (7)	GREASE QTY. BOTTOM CHAMBER (7)
				D	D1	D2	d1-d2 (Min-Max) (2)(3)	l1-l2	a	G	S(4)						
MTV	Nm	Nm	rpm	D	D1	D2	d1-d2 (Min-Max) (2)(3)	l1-l2	a	G	S(4)	kg	kg	J(kgm ²)	kg	kg	
42	1.200	2.400	8.600	116	80	60	13-44	55	8	3	75	5	4	0,006	0,018	0,017	
55	2.600	5.200	6.600	152	100	79	16-58	70	8	3	90	10	7	0,021	0,038	0,032	
70	5.000	10.000	5.600	178	125	101	20-75	80	8	3	108	17	12	0,048	0,056	0,046	
90	8.600	17.200	4.700	213	148	124	25-95	95	9	3	124	29	19	0,125	0,100	0,068	
100	14.000	28.000	4.200	240	173	143	30-105	105	9	3	136	44	31	0,20	0,184	0,142	
125	20.600	41.200	3.600	279	204	170	35-130	120	12	5	158	68	45	0,48	0,279	0,210	
145	33.000	66.000	3.150	318	242	205	45-150	135	13	5	172	100	66	0,90	0,392	0,298	
165	45.600	91.200	2.860	346	268	216	55-165	150	13	5	192	134	89	1,45	0,669	0,511	
185	61.400	122.800	2.580	389	302	250	60-190	170	14	5	210	190	122	2,70	1,052	0,865	
205	80.800	161.600	2.320	425	327	275	70-210	185	16	6	230	255	166	4,15	1,465	1,240	
230	105.500	211.000	2.200	457	354	300	100-230	200	16	6	250	285	179	5,60	1,996	1,727	
260	161.000	322.000	2.000	527	410	340	115-260	230	16	6	280	420	266	9,35	3,097	2,641	

From size 185 (included) the coupling is supplied by default with puller holes. If required, puller holes can also be made for smaller sizes.

Setscrews can be included upon request.
Adapted hub length available upon request.

ATEX certifications are available. Please, contact JAURE to define the zone and category.



(1) The torque of the coupling does not include the connection transmission capacity.

(2) Minimum dimensions refer to already machined bore.

For A00 rough bore dimensions contact Jaure.

(3) Max. allowable bore for couplings with DIN 6885/1 keys.

For other types of keys or connections please consult JAURE.

(4) Clearance to align coupling hubs and replacement of sealing rings.

(5) Weight and moment of inertia are given for minimum bore.

(6) Weight is given for maximum bore.

(7) The amount of grease indicated in the catalogue is for guidance only.



For exact amount please refer to coupling instructions.

(8) n MAX speed for balanced couplings. For higher speeds contact Jaure.

Technical modifications reserved

Other information MT Designs & References

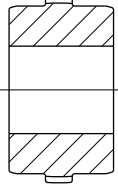
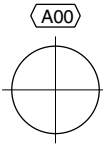
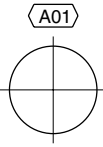
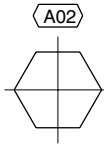
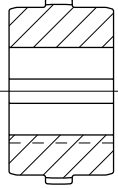
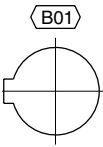
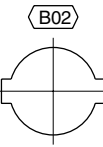
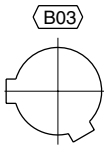
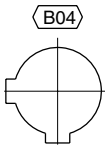
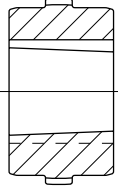
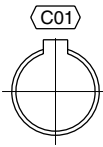
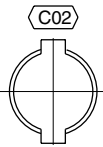
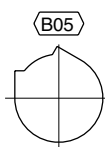
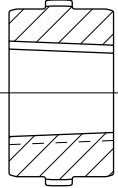
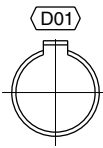
Shaft Connections Types

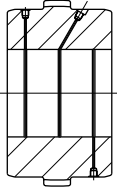
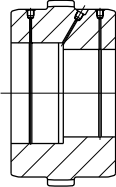
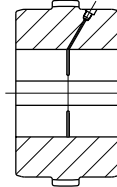
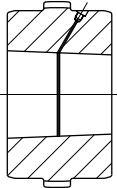
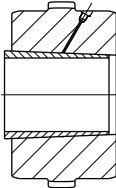
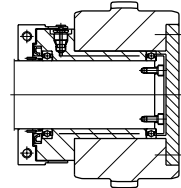
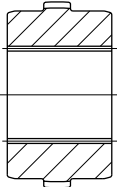
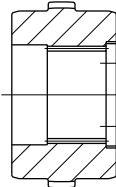
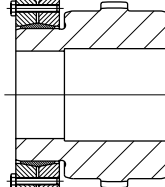
	 A00 Pilot	 A01 Cylindrical	 A02 Hexagonal		
	 B01 One keyway	 B02 Two keyways at 180°	 B03 Two keyways at 120°	 B04 Two keyways at 90°	
	 C01 Conical bore One straight keyway	 C02 Conical bore Two straight keyways	 B05 Two tangential keyways at 120°		
	 D01 Conical bore One tapered keyway	 D02 Conical bore Two tapered keyways			
	E01 Shrink fit		E02 Shrink fit with two diameters		E03 Shrink fit and keyway
	F01 Tapered Shrink fit		F02 With conical sleeve		F03 With Safeset®
	G01 According DIN 5480		G02 According DIN 5480 With centering diameter		G03 With clamping ring

Technical modifications reserved

Recommendations For Shaft/Bore Fits

The following recommendations, according to ISO, are given for shaft/bore fits.

TYPE OF FIT	SHAFT TOLERANCES	BORE TOLERANCES
Interference fits with parallel keyway	h 6	S 7
	k 6	M 7
	m 6	K 7
	n 6	J 7
	p 6	H 7
Shrink fits* without parallel key	u 6	H 7
	v 6	
	x 6	

* The stresses on the hub must be checked.

For other types of connection please consult our technical department. For one keyway a keyway tolerance width ISO P9 is recommended. For double keyway ISO JS9 is recommended.

Axial Forces Induced By Gear Couplings

Gear couplings accommodate the misalignment through the sliding of the hub teeth over the sleeve teeth. This sliding imposes axial forces at the nearby bearings. This force has to be taken into account when designing the machine and the thrust bearings:

$$F_a = \frac{2 \times T_n \times \mu}{\varnothing_p \times 0,94}$$

F_a = Axial Force (KN)

T_n = Nominal Torque to be transmitted (KNm)

μ = Friction coefficient ($\mu=0,05$ for good lubrication, $\mu = 0,3$ for axial lock up)

\varnothing_p = Pitch diameter of the gear mesh (in meters), Take D1 from catalogue as an approximate dimension or consult Jaure for a more accurate calculation.

MT Designs

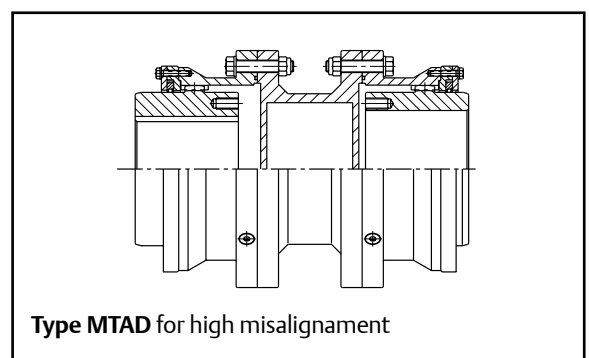
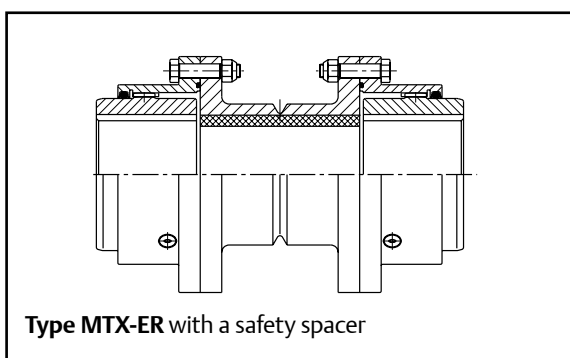
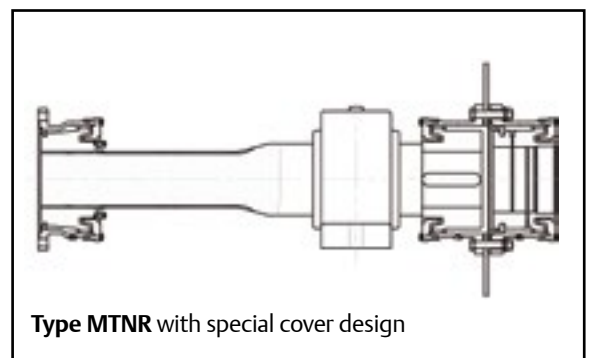
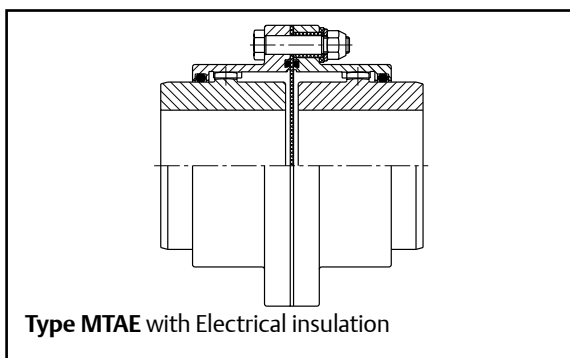
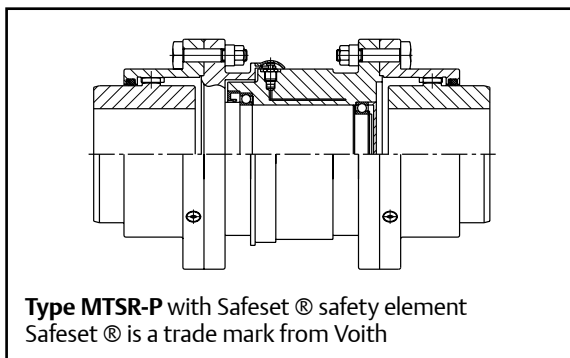
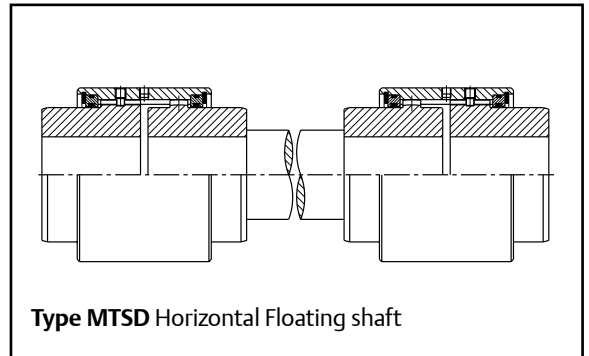
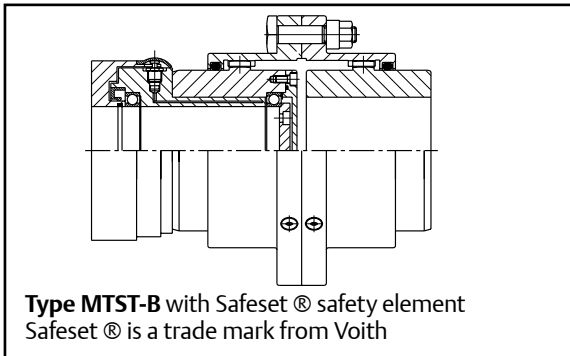

MT Designs

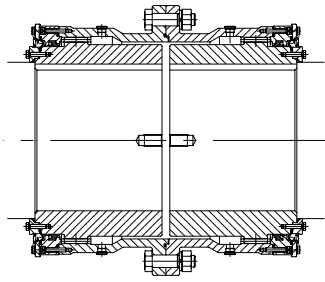

Type MT-UW for underwater

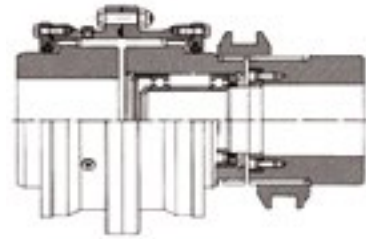

Type MTEL Disengaging Coupling

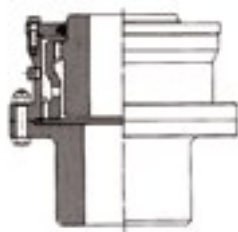

Type MTVS Vertical Coupling

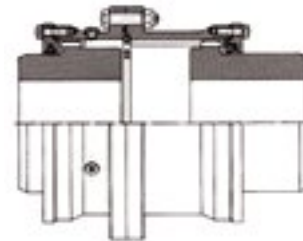

Type MTNCO special Telescopic Coupling



Type MTL Limited end Float

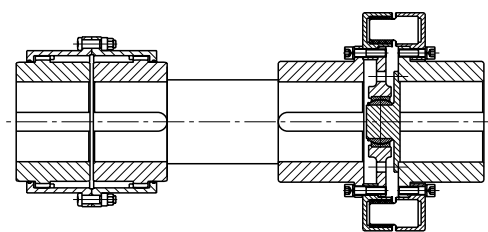

Type MT in combination with an elastic coupling

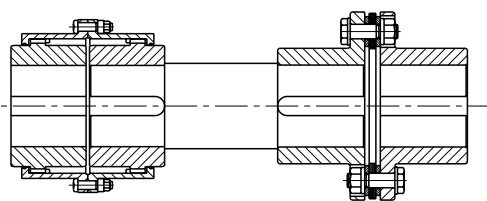

Type MT in combination with a disc pack coupling

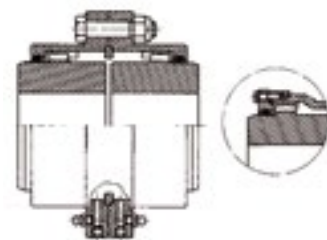

Type SID Metallurgy Standard (FRANCE)

MT Designs

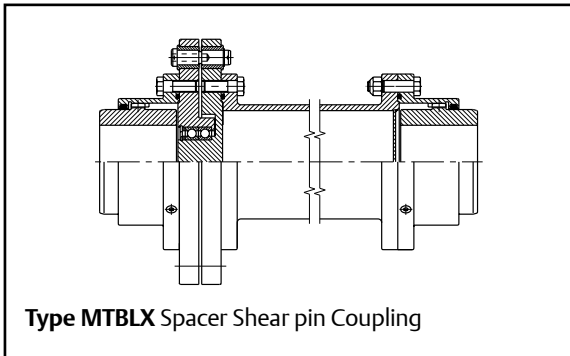

Type MTBLX Spacer Shear pin Coupling

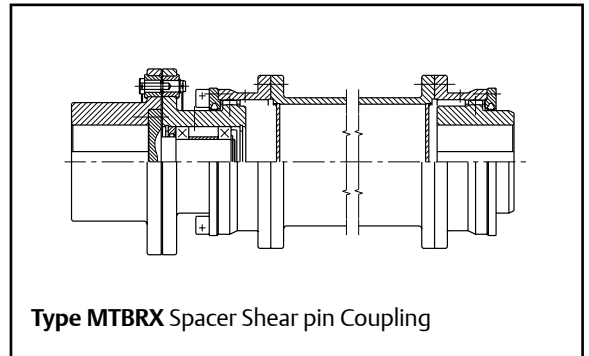

Type MTBRX Spacer Shear pin Coupling

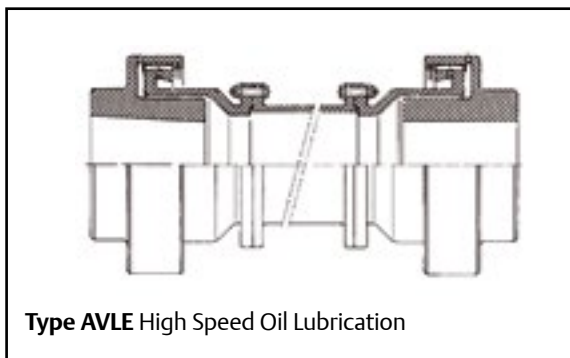

Type AVLE High Speed Oil Lubrication

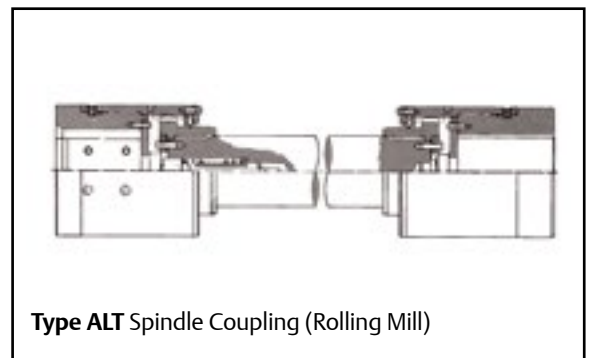

Type ALT Spindle Coupling (Rolling Mill)

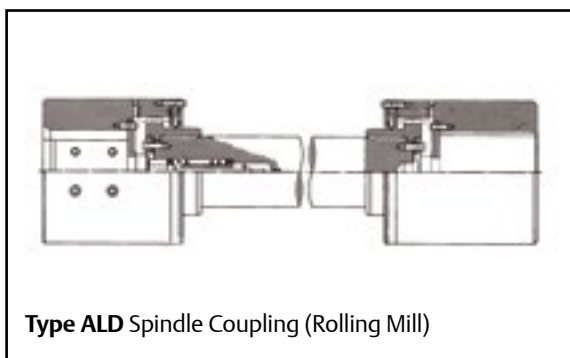

Type ALD Spindle Coupling (Rolling Mill)

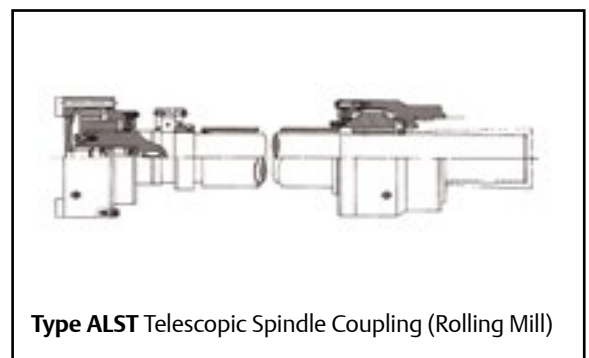

Type ALST Telescopic Spindle Coupling (Rolling Mill)

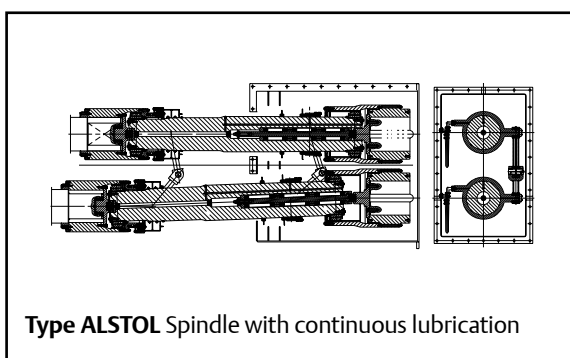

Type ALSTOL Spindle with continuous lubrication

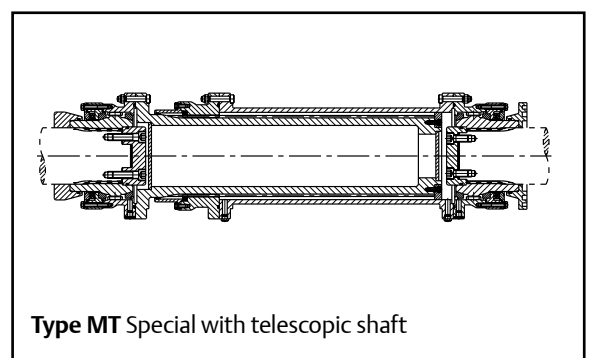

Type MT Special with telescopic shaft

Required Minimum Data

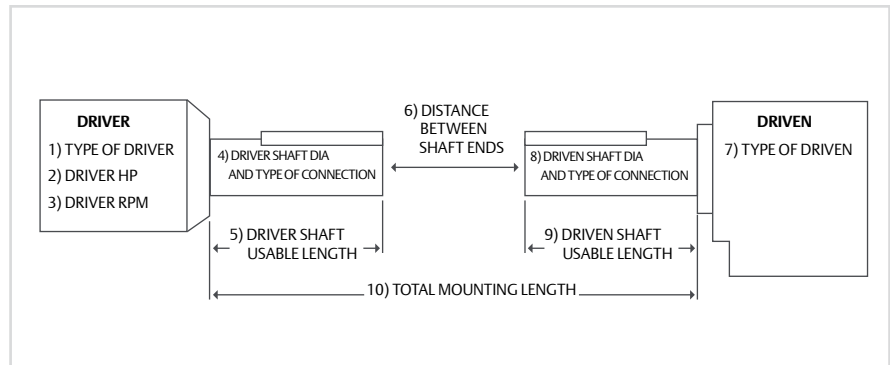

1. Type of driver (Electric Motor, Combustion Engine, Gearbox, etc.):

2. Driver Power:

3. Operating Speed (rpm):

4. Driver Shaft Diameter:
Type of connection (hub to shaft connection):

5. Driver Usable Shaft Length:
(Measure from the end of the shaft to any obstruction)

6. Distance between shaft ends (DBSE):

7. Type of Driven Equipment:

8. Driven Shaft Diameter:
Type of connection (hub to shaft connection):

9. Driven Usable Shaft Length:
(Measure from the end of the shaft to any obstruction)

10. Total Mounting Length:
(Advise of any obstructions, walls, beams, guards, pipes, etc.)

11. Misalignment:
Angular:
Offset:
Axial:

12. Ambient temperature:

13. Potential excitation or critical frequencies:
(Torsional, Axial, Lateral)

14. Space limitations:

15. Limitation on coupling generated forces:
(Axial, Moments, Unbalance)

16. Balance requirements:

MT References:

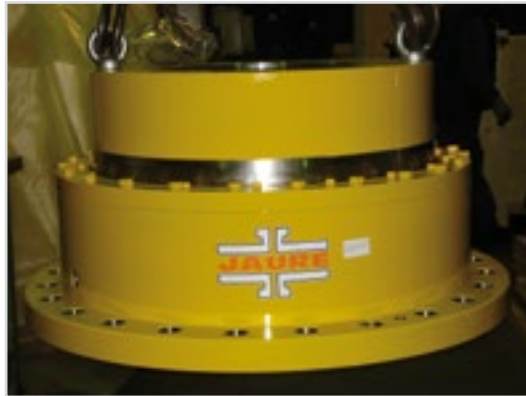

Steel main drive gear coupling



Heavy duty MT gear couplings



Intermediate gear coupling for HRM



Disengaging gear with lever



Gear inspection in CMM



Gear coupling with brake



Gear coupling with JCFS carbon fiber shaft



Shear pin gear couplings in steel mill



Disengaging gear coupling with pneumatic lever



Jaure gear spindles



MT gear hub



Jaure MTGX-HD-TI-1000 on wind test bench

MT References:



Jaure gear with JGFS glass fiber composite spacer



In house testing of pneumatic lever

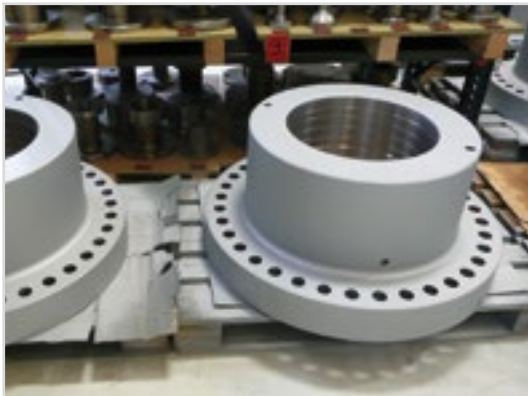

Jaure PLMT rigid coupling



Jaure gear coupling with brake for hoisting



Jaure gear coupling for underwater operation



Shear pin type gear coupling



Jaure MTG gear couplings



Nitrided gear hub



Case carburized gear spindles



Dredger gear coupling



Gear clutching



Packing of MTG-HD gear coupling

Jaure manufacturing program



Product Brand Name	MT	LAMIDISC®	TCB / TCB-HD	AL-S / AL-SD / ALD	RECORD
Type & Description	Gear	Disc pack	Barrel (drum type)	Gear spindles	Grid / spring type

INDUSTRY APPLICATION					
Metals & Heavy duty	•	•	•	•	•
Minerals & Mills	•	•	•		•
Crane & Hoisting	•	•	•		•
Pulp & Paper	•	•			•
Petrochemical / Oil & Gas	•	•			•
Cooling Towers		•			
Machine Tools		•			
Marine	•	•	•		
Wind Turbines		•			•
Test Benches	•	•			
Railway	•	•			



Special safety heavy duty gas nitrided gears

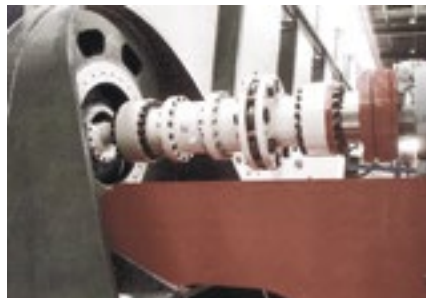

LAMIDISC® Safety coupling on test bench Incl. SAFESET® (SAFESET® from VOITH TURBO)



Type Approvals (Marine & Wind).

COUPLINGS



JAUFLEX®

IXILFLEX®

COMPOLINK®

**JFTL TORQUE
LIMITER**

JCFS

JHC

Elastic

Elastic Link

Composite Link

Torque Limiter

Composite Shafts

Hydraulic fit
(shaft couplings)

•			•		•
•			•		•
•			•		
•	•	•		•	
•		•		•	
		•		•	
•		•		•	
•	•	•	•	•	•
•	•	•	•	•	•
	•	•		•	•
	•	•	•		



Carbon Fibre Shaft combined with LAMIDISC® coupling.



Torque monitoring on wind turbines.



Double-gear couplings for railway.

Kop-Flex & Jaure manufacturing program

COUPLINGS



Product Brand Name	MAX-C®	HIGH PERFORMANCE PROGRAM			KOPFLEX GREASE	SERVICE
Type & Description	Heavy duty elastic coupling	GEAR	DISC	DIAPHRAGM	Gear coupling / spindle grease	Repair & maintenance program

INDUSTRY APPLICATION

Metals & Heavy duty	•				•	•
Minerals & Mills	•				•	•
Crane & Hoisting	•				•	•
Pulp & Paper					•	•
Petrochemical / Oil & Gas	•	•	•	•	•	•
Cooling Towers					•	•
Machine Tools					•	•
Marine	•	•	•	•	•	•
Wind Turbines	•				•	•
Test Benches	•	•	•	•	•	•
Railway	•	•			•	•

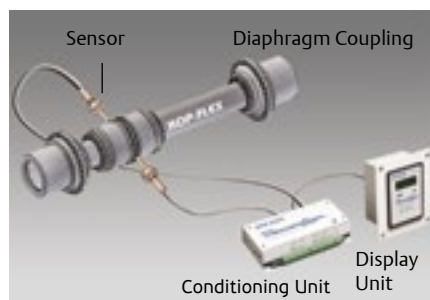

Powerlign® Torque Monitoring.



High Performance Solutions.

Global presence

MANUFACTURING FACILITIES & ENGINEERING CENTERS



JAURE® & KOP-FLEX® engineered couplings are designed, manufactured, sold and serviced worldwide, with service provided from specification right through to installation.

All JAURE® & KOP-FLEX® facilities around the globe are state of the art, with access to a large and

experienced engineering staff focused on providing solutions for our customers' requirements.

A dedicated global sales and service team assists you to find the best choice and manage all your coupling needs.



JAURE®. Zizurkil, Spain.



Pune, India.



Nove Mesto, Slovakia.



Zhangzhou, China.



KOP-FLEX®. Baltimore, USA.



Florence, Kentucky, USA.



Rexdale / Toronto, Canada.



Apocadaca, México.

JAURE®

Regal Beloit Spain S.A
Ernio bidea, s/n
20159 ZIZURKIL
(Gipuzkoa) SPAIN

Phone: +34 943 69 00 54

Fax: +34 943 69 02 95

www.RegalPTS.com/jaure

APPLICATION CONSIDERATIONS

The proper selection and application of power transmission products and components, including the related area of product safety, is the responsibility of the customer. Operating and performance requirements and potential associated issues will vary appreciably depending upon the use and application of such products and components. The scope of the technical and application information included in this publication is necessarily limited. Unusual operating environments and conditions, lubrication requirements, loading supports, and other factors can materially affect the application and operating results of the products and components and the customer should carefully review its requirements. Any technical advice or review furnished by Regal-Beloit America, Inc. and its affiliates with respect to the use of products and components is given in good faith and without charge, and Regal assumes no obligation or liability for the advice given, or results obtained, all such advice and review being given and accepted at customer's risk.

For a copy of our Standard Terms and Conditions of Sale, Disclaimers of Warranty, Limitation of Liability and Remedy, please contact Customer Service at 1-800-626-2120. These terms and conditions of sale, disclaimers and limitations of liability apply to any person who may buy, acquire or use a Regal Beloit America Inc. product referred to herein, including any person who buys from a licensed distributor of these branded products.

A Regal Brand



REGAL

www.regalbeloit.com