

Beschreibung

Zentrische Absperrklappe mit Elastomer-Manschette für Flüssigkeiten und Gase im Industriebereich sowie Gebäudetechnik, Wasseraufbereitung, ...

Merkmale

- Gehäusebauformen D1 Wafer DN 25-1000
D3 Lug DN 25-600
D4 U-förmig DN 150-1600
- Einbaulänge nach ISO 5752/20, EN 558-1/20
- Konstruktion nach EN 593 / API 609 category A (auf Anfrage)
- Kopfflansch nach EN ISO 5211
- Max. Betriebsdruck 16 bar
- Anschlussnormen PN6, PN10, PN16, ANSI cl. 150
- Temperaturbereich -20°C ÷ 140°C je nach Werkstoff
- Dichtheitsprüfung nach EN 12266-1/P12 Leckrate A, Prüfmedium Wasser
nach API 598 (auf Anfrage)

CE

Die Absperrklappen DESPONIA erfüllen die Sicherheitsanforderungen des Anhangs I der Europäischen Druckgeräterichtlinie 2014/68/UE (PED) für Fluide der Gruppen 1 und 2.

SIL

Die Absperrklappen DESPONIA eignen sich für den Einsatz in sicherheitstechnischen Systemen nach IEC 61508 / 61511, Sicherheitsintegritätslevel SIL 2.



D1
Wafer

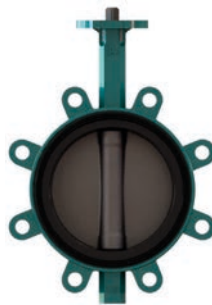

D3
Lug



D4
U-förmig

Konstruktion

1	Gehäuse (hoher Klappenhs ermöglicht Isolierung der Leitung)
2	Nicht ausblasbare Welle mit Stellungsanzeige
3	Scheibe
4	Auswechselbare Manschette mit Dichtrillen auf der Dichtfläche
5	Wellenlager, DN25-400 Resicoat®, DN450-1600 Bronze
6	Äussere Wellenabdichtung
7	Haltescheibe (Ausblsassicherung)

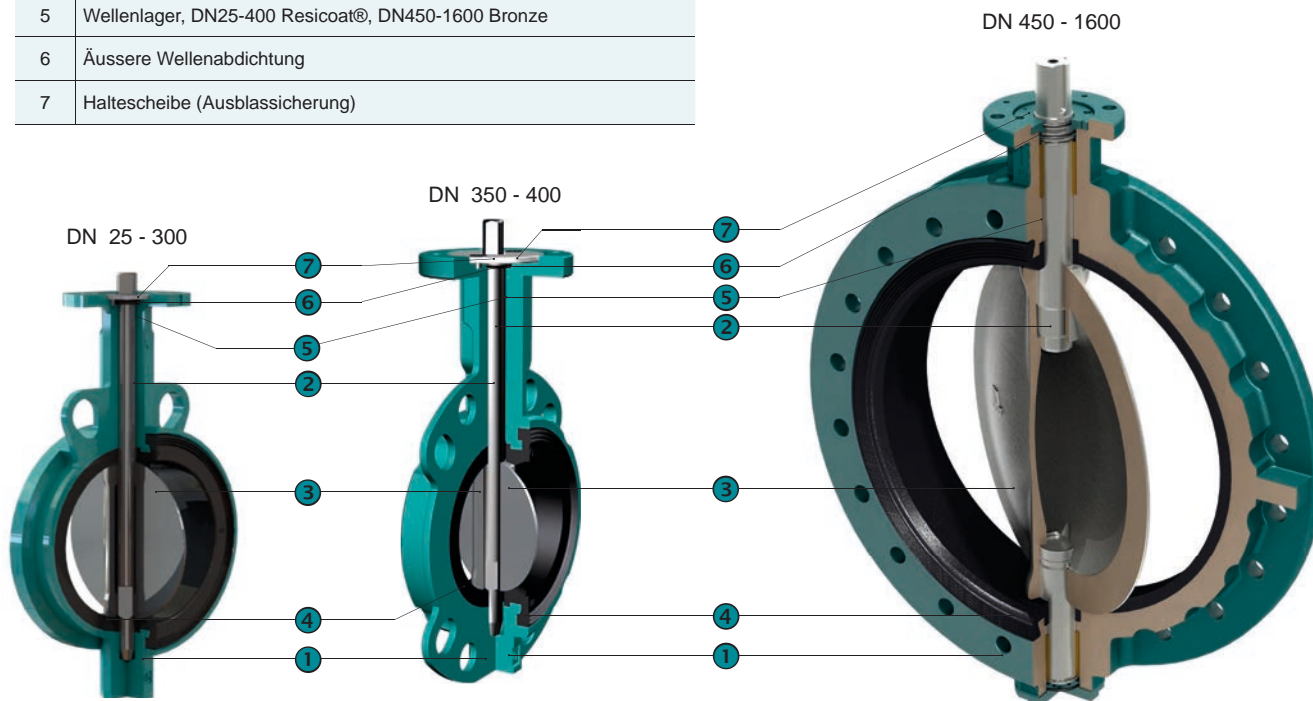

Kv Werte m³/h

Öffnungswinkel der Klappe

DN	20°	30°	40°	50°	60°	70°	80°	90°
25/32		1,5	5	10	15	26	34	40
40		2,7	8,5	16	25	37	46	50
50	2	7	15	28	45	68	88	100
65	3	11	24	48	85	138	180	210
80	8	22	50	83	134	230	312	360
100	15	35	70	130	225	410	585	650
125	28	70	135	230	360	600	920	1050
150	33	95	205	320	580	980	1410	1620
200	60	175	355	580	910	1600	2450	2800
250	132	340	590	940	1480	2550	3950	4480
300	200	505	890	1450	2100	3800	5960	6800
350	280	680	1200	2050	3150	5050	8100	9200
400	365	860	1500	2490	3980	6600	10200	11700
450	465	1080	1900	3150	5050	8700	13300	15200
500	580	1200	2300	3740	6150	11000	16800	18900
600	820	1600	2780	5200	8940	14500	23500	26800
700	890	2050	3450	6050	11050	18800	31500	37100
800	1300	2550	4950	8750	14200	23500	39500	48500
900	1650	3300	6400	11800	19400	31500	52500	61300
1000	2150	4250	8200	15100	23500	39400	65500	80500
1200	4000	7500	12500	19800	34000	55400	98300	119200
1400	5200	10120	18200	32500	51500	89500	142000	162000
1600	7100	14210	26050	45000	71200	118500	196200	228500

Typenschlüssel

D1 0100 . 3 3 - 2KR . 41 . 2AR . E
 ① ② ③ ④ ⑤ ⑥ ⑦ ⑧



①	Gehäuseform	D1	Wafer (Ringgehäuse)	DN25-1000	
		D3	Lug Gehäuse	DN25-600	
		D4	U-förmiges Gehäuse	DN150-1600	
②	Nennweite	0025-1600	mm		
③	Betriebsdruck	0	2,5 bar	DN100-1600	
		1	6 bar	DN350-1600	
		*	10/16/20 bar, siehe Tabelle unten		
④	Anschlussnorm	**	PN6/10/16 siehe Tabelle unten. Andere Normen auf Anfrage		
⑤	Gehäuse	1AE	Grauguss EN-GJL-250, Polyurethan beschichtet 80µ	< 140°C	DN450-1600
		2KR	Sphäroguss EN-GJS-400-15, Epoxy (Resicoat®) beschichtet 200µ, Wafer und Lug	< 110°C ¹⁾	DN25-300
		2AR	Sphäroguss EN-GJS-400-15, Epoxy (Resicoat®) beschichtet 200µ U-förmig	< 110°C ¹⁾	DN150-300
			Sphäroguss EN-GJS-400-15, Epoxy (Resicoat®) beschichtet 200µ	< 110°C ¹⁾	DN350-400
		2AE	Sphäroguss EN-GJS-400-15, Polyurethan beschichtet 80µ	< 140°C	DN450-1600
2AN	Sphäroguss EN-GJS-400-15, Polyurethan beschichtet 250µ	< 140°C	DN450-1600		
⑥	Welle	41	Edelstahl 1.4021, AISI420	DN25-300	
		42	Edelstahl 1.4542 / 17-4PH	DN25-300	
		4A	Edelstahl 1.4021, AISI420	DN350-1600	
		4L	Edelstahl 1.4542 / 17-4PH	DN350-1600	
⑦	Scheibe	2AR	Sphäroguss EN-GJS-400-15, Rilsan beschichtet 250µ	< 90°C	DN25-700
		2AE	Sphäroguss EN-GJS-400-15, Polyurethan beschichtet 80µ	< 120°C	DN800-1600
		2AC	Sphäroguss EN-GJS-400-15, Chrom beschichtet		DN25-600
		2AH	Sphäroguss EN-GJS-400-15, Halar beschichtet min. 600µ	< 70°C	
		3OD	Stahl 1.0552 / GS52.3, Ultralene Coating™ ausgekleidet < 80°C, pmax. 10 ≤ DN300 / 6 bar > DN800		DN80-300, 800-1400
		4C0	Edelstahl 1.4408 ≈ CF8M		
		4CP	Edelstahl 1.4408 ≈ CF8M poliert		DN25-600
		4CQ	Edelstahl 1.4408, PEKK beschichtet min. 400µ	< 200°C	
		4S0	Super austenitischer Stahl 1.4588		
		5C0	Alubronze ASTM B148 C95800 / G-Cu Al 10 Ni		
⑧	Manschette	7H0	Hastelloy ASTM A494 CW-12MW		≥ DN450 auf Anfrage
		E	EPDM	< 95°C pmax DN25-1200 = 16 bar, DN1400-1600 = 10 bar	
		EE	EPDM DVGW, ACS, WRAS, NSF-61, EN681-1	< 95°C pmax DN25-1200 = 16 bar, DN1400-1600 = 10 bar	
		EC	EPDM HT	< 130°C pmax DN25-1200 = 16 bar, DN1400-1600 = 10 bar	
		N	Nitril (NBR)	< 100°C pmax DN25-300 = 16 bar, DN350-1600 = 10 bar	
		H	CSM (Hypalon)	< 110°C pmax DN25-300 = 16 bar, DN350-1600 = 10 bar	
		V	FPM (Viton)	< 200°C pmax DN25-300 = 16 bar, DN350-1600 = 10 bar	
		Andere Manschettenwerkstoffe und weisse Ausführungen auf Anfrage			

1) Für Temperaturen zwischen 110 und 140 °C, ist die Klappe nur bis zur nächst tieferen Druckklasse dicht (z.B. PN16 Klappe, max. 10 bar)

* Betriebsdruck (Code)

Gehäusematerial	DN→	25	32	40	50	65	80	100	125	150	200	250	300	350	400	450	500	600	700	800	900	1000	1200	1400	1600	
EN-GJL-250 (1A)	6 bar																									1
	10 bar																									
EN-GJS-400-15 (2A/2K)	10 bar																									
	16 bar																									

**Anschlussnorm (Code)

DESPONIA	DN→	25	32	40	50	65	80	100	125	150	200	250	300	350	400	450	500	600	700	800	900	1000	1200	1400	1600	
 D1	PN6																									
	PN10																									
	PN16																									
	ANSI cl. 150																									
 D3	PN10																									
	PN16																									
	ANSI cl. 150																									
 D4	PN10																									
	PN16																									
	ANSI cl. 150																									

Max. Druck- und Temperatureinsatzgrenzen sind von den Betriebsbedingungen abhängig. Andere Ausführungen auf Anfrage!

Abmessungen

D1 Ringgehäuse, DN25-1000

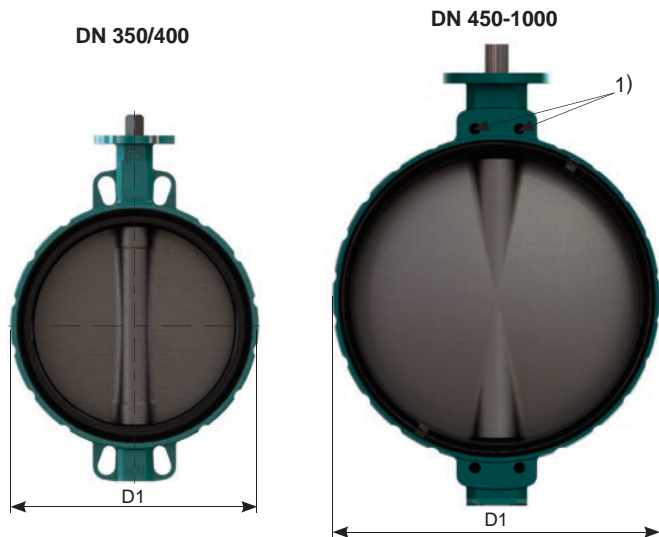
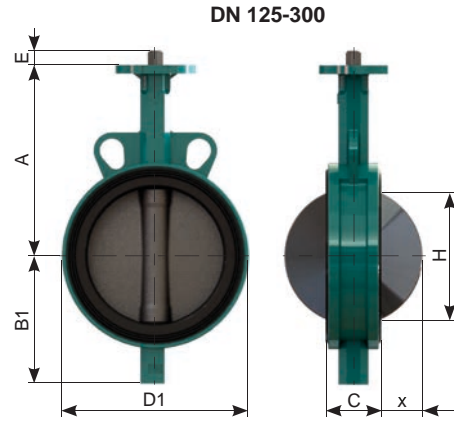
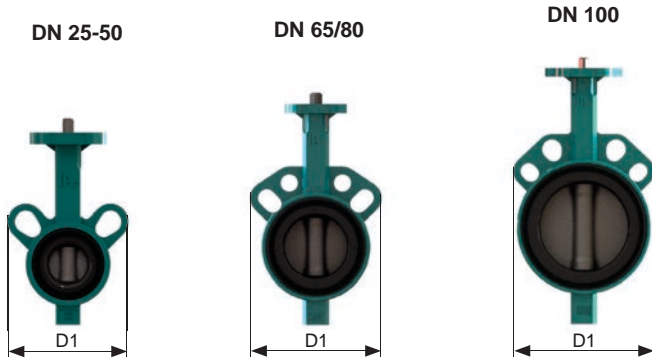

1) DN 450 - 1600, 2 x Gewinde am Klappen Hals und -fuss

DN	A	B1	C	D1	E	H*	x*	[kg]
(25)32	110	51	30	101	12	19	3	1,0
40	130	55	33	108	12	28	6	1,3
50	135	72	43	120	12	32	6	1,8
65	150	82	46	138	12	50	11	2,3
80	160	92	46	142	12	69	19	2,3
100	180	110	52	162	12	88	26	3,9
125	195	128	56	181	16	115	36	5,0
150	210	141	56	205	16	141	48	5,9
200	240	174	60	260	19	194	72	9,3
250	279	201	68	310	24	240	91	17,0
300	315	234	78	362	24	290	112	23,7
350	330	268	80	425	40	330	130	41,5
400	365	299	102	475	40	377	145	57,2
450	397	355	113	538	65	425	164	95
500	437	393	126	595	65	474	182	125
600	522	464	153	695	80	569	218	180
700	565	503	168	800	80	660	257	280
800	627	577	190	908	80	774	304	387
900	696	643	204	1015	100	855	337	502
1000	745	693	218	1133	100	960	383	710

* Bei Verwendung von Kunststoff-Bundbüchsen Mass H/x (Scheibenaustrittsmass) unbedingt beachten

D3 LUG-Gehäuse, DN 25-600

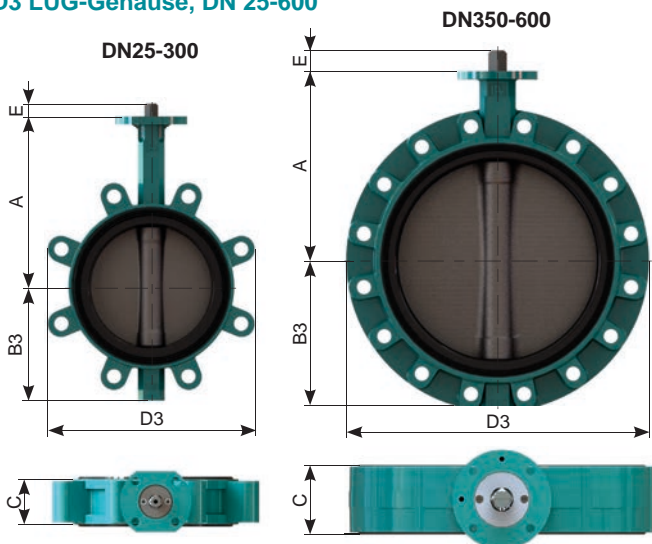

DN	A	B3	C	D3	E	H*	x*	[kg]
25	110	51	30	101	12	19	3	1,5
32	110	51	30	101	12	19	3	1,5
40	130	54	33	108	12	28	6	1,9
50	135	72	43	116	12	32	6	2,4
65	150	82	46	131	12	50	11	4,8
80	160	88	46	188	12	69	19	4
100	180	102	52	219	12	88	26	6,2
125	195	116	56	248	16	115	36	7,7
150	210	128	56	274	16	141	48	8,4
200	240	161	60	332	19	194	72	16,6
250	279	199	68	402	24	240	91	23,5
300	315	234	78	472	24	290	112	32,4
350	330	258	80	520	40	330	130	55
400	365	290	102	584	40	377	145	75
450	397	355	113	655	65	425	164	150
500	437	393	126	712	65	474	182	170
600	522	464	153	829	80	569	218	240

Abmessungen

D4 U-förmiges Gehäuse, DN 150-1600

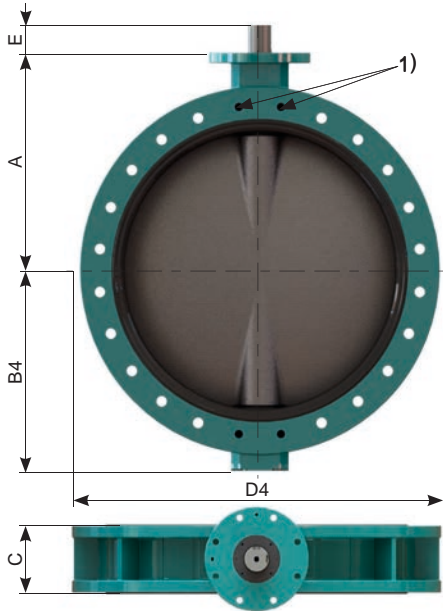

DN	A	B4	C	D4	H*	x*	J	E	[kg]
150	210	143	56	285	141	48	10	16	15
200	240	170	60	340	194	72	12,5	19	19,5
250	279	200	68	406	240	91	15	24	30,5
300	315	239	78	482	290	112	15	24	44
350	330	265	80	533	330	130	18	40	59
400	365	296	102	597	377	145	20	40	82
450	397	355	113	640	425	164	24	65	118
500	437	393	126	715	474	182	26	65	175
600	522	464	153	840	569	218	28,5	80	260
700	565	503	168	927	660	257	31,5	80	345
750	590	541	170	985	709	272	34	80	435
800	627	577	190	1060	774	304	36,5	80	510
900	696	643	204	1170	855	337	38	100	660
1000	745	693	218	1255	960	383	44	100	790
1100	820	738	218	1395	1054	429	44	100	850
1200	881	806	254	1485	1149	462	47	120	1180
1400	990	908	280	1746	1336	543	40	120	1700
1600	1117	1048	318	1924	1553	634	50	155	2600

1) DN 450 - 1600, 2 x Gewinde am Klappenhals und -fuss

Kopfflansch nach ISO 5211

Wafer und Lug

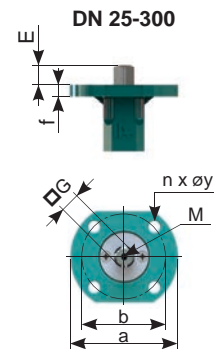

U-förmig

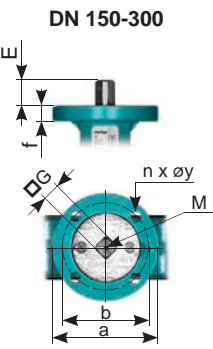

Wafer und Lug

DN	E	G	M	f	ISO	a	b	n x øy
25-40	12	□ 8	M4	10	F05*	65	50	4 x 7
50-80	12	□ 11	M6	10	F05	65	50	4 x 7
100	12	□ 11	M6	10 / 10	F05 / F07	65 / 89	50 / 70	4 x 7 / 4 x 9,5
125	16	□ 14	M6	10 / 10	F05 / F07	65 / 89	50 / 70	4 x 7 / 4 x 9,5
150	16	□ 14	M6	10	F07	89	70	4 x 9,5
200	19	□ 17	M6	10	F07	89	70	4 x 9,5
250-300	24	□ 22	**	18	F10/F12	150	102/125	4 x 11 / 4 x 13

*F04 auf Anfrage

**Wellenende ohne Gewinde

U-förmig

DN	E	G	M	f	ISO	a	b	n x øy
150	16	□ 14	M6	12	F07	90	70	4 x 9
200	19	□ 17	M6	12	F07	90	70	4 x 9
250-300	24	□ 22	**	18	F10/F12	150	102/125	4 x 11 / 4 x 13

**Wellenende ohne Gewinde

Wafer, Lug und U-förmig

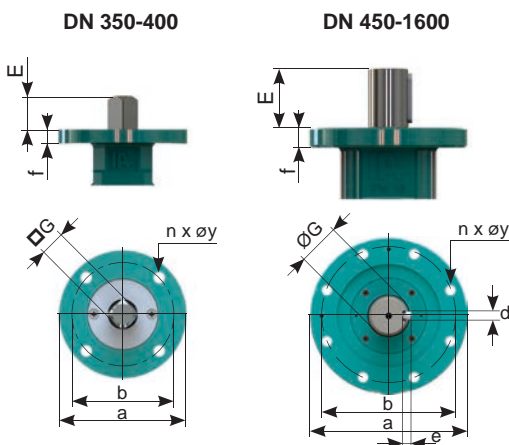

Wafer, Lug und U-förmig

DN	E	G	d	e	f	ISO	a	b	n x øy
350	40	□ 22	-	-	18	F12	155	125	4 x 13
400	40	□ 27	-	-	18	F12	155	125	4 x 13
450-500	65	Ø 45	14	9	25	F14	175	140	4 x 18
600	80	Ø 70	20	12	25	F16	220	165	4 x 22
700	80	Ø 70	20	12	25	F25	300	254	8 x 18
(750)	80	Ø 70	20	12	30	F25	300	254	8 x 18
800	80	Ø 70	20	12	30	F25	300	254	8 x 18
900	100	Ø 80	22	14	30	F30	350	298	8 x 22
1000	100	Ø 80	22	14	30	F30	350	298	8 x 22
(1100)	100	Ø 80	22	14	30	F30	350	298	8 x 22
1200	120	Ø 100	28	16	30	F30	350	298	8 x 22
1400	120	Ø 120	32	18	35	F30	350	298	8 x 22
1600	155	Ø 130	32	18	40	F35	418	356	8 x 33,5

Abmessungen

Handhebel

Gehäusetyp Wafer und Lug

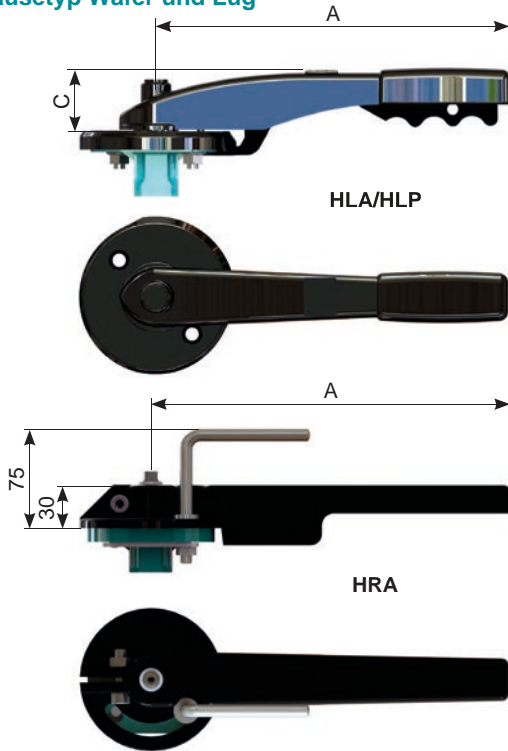

Aluminium, Epoxy beschichtet

DN		A	C	[kg]
25-40	HLA.F0508.180K	180	41	0.4
50-65	HLA.F0511.180K	180	41	0.4
80	HLA.F0511.240K	243	43	0.5
100	HLA.F0711.240K	243	43	0.5
125-150	HLA.F0714.340K	340	51	0.6
200 ¹⁾	HLA.F0717.340K	340	51	0.6

Polyamide PA 6, 30% verstärkt mit Glasfasern

DN		A	C	[kg]
50-80	HLP.F0511.240K	240	61	0.6
100	HLP.F0711.240K	240	61	0.6
125-150	HLP.F0714.240K	240	61	0.6
200 ¹⁾	HLP.F0717.390K	390	66	0.9

Aluminium, Epoxy beschichtet

DN		A	[kg]
25-40	HRA.F0508.180K	180	0.4
50-65	HRA.F0511.180K	180	0.4
80	HRA.F0511.250K	250	0.5
100	HRA.F0711.250K	250	0.6
125-150	HRA.F0714.340K	340	0.6
200 ¹⁾	HRA.F0717.340K	340	0.6

1) Für Severe Conditions, LF und FF, muss ein Getriebe verwendet werden

Gehäusetyp U-förmig

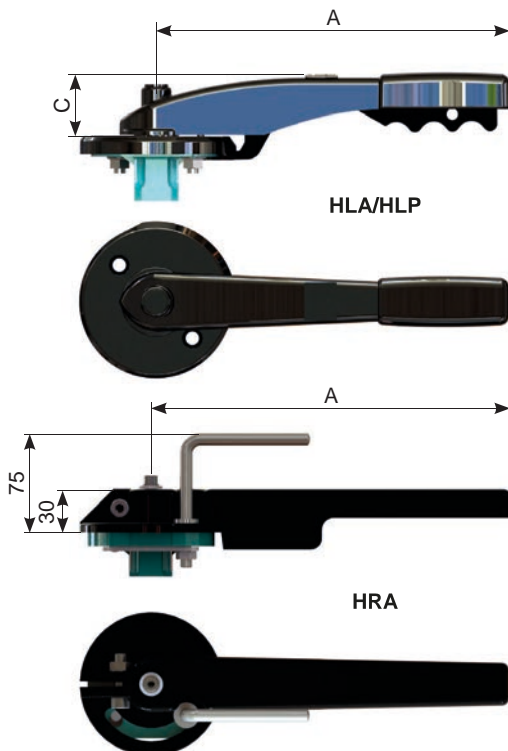

Aluminium, Epoxy beschichtet

DN		A	C	[kg]
150	HLA.F0714.340K	340	51	0.6
200 ¹⁾	HLA.F0717.340K	340	51	0.6

Polyamide PA 6, 30% verstärkt mit Glasfasern

DN		A	C	[kg]
150	HLP.F0714.240K	240	61	0.6
200 ¹⁾	HLP.F0717.390K	390	66	0.9

Aluminium, Epoxy beschichtet

DN		A	[kg]
150	HRA.F0714.340K	340	0.6
200 ¹⁾	HRA.F0717.340K	340	0.6

1) Für Severe Conditions, LF und FF, muss ein Getriebe verwendet werden

Abmessungen

Getriebe

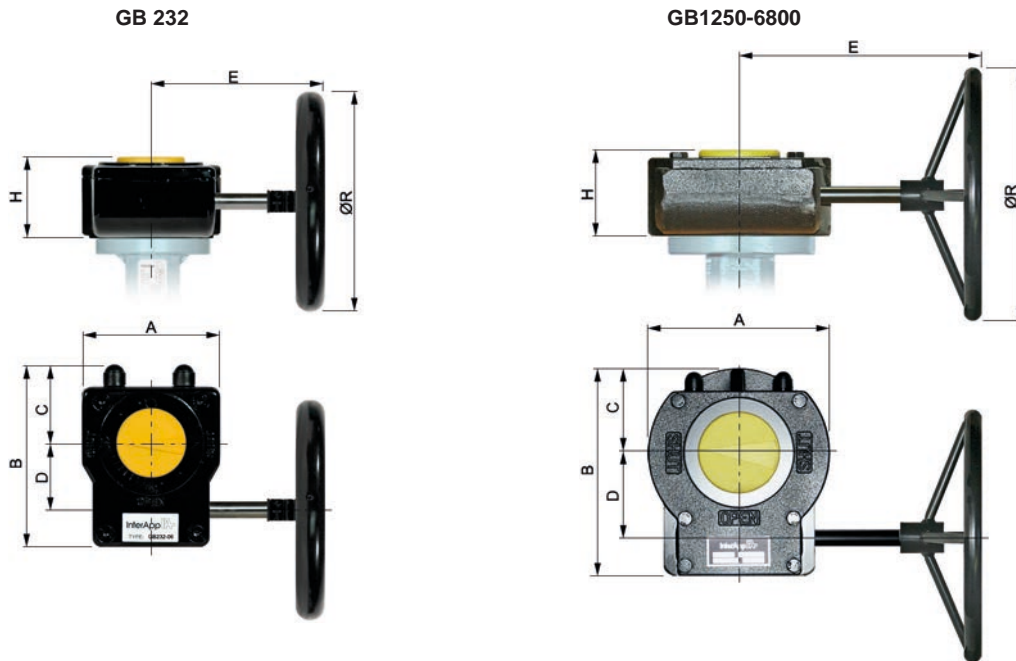

Für Flüssigkeiten 20°C - 80°C, p_{max} DN25-300 ...16 bar, DN350-1600 ... 10 bar

DN		A	B	C	D	E	H	ØR	n*	[kg]
25-40	GB232-05.F05-F0708.100	80	114	48	42.5	121	53	100	10	0.8
50-100	GB232-05.F05-F0711.100	80	114	48	42.5	121	53	100	10	0.8
125-150	GB232-05.F05-F0714.100	80	114	48	42.5	121	53	100	10	0.8
200	GB232-06.F05-F0717.160	80	114	48	42.5	180	59	160	10	0.9
250-300	GB232-08.F07-F1022.250	100	131	56	50	216	67	250	9.25	1.55
350	GB232-13.F10-F1222.300	175	209	83	80	361	84	300	10	5.4
400	GB232-13.F10-F1227.500	175	209	83	80	396	84	500	10	5.4
450	GB1250N.F1445.400	220	258	110	104.5	326	102	400	13.75	22
500	GB1250N.F1445.400	220	258	110	104.5	326	102	400	13.75	22
600	GB2000N.F1670.500	241	255	106	53	348	121	500	27	24
700	GB2000NLB.F2570.600-SH100	285	293	142	53	348	121	600	27	27
750	GB2000NLB.F2570.700-SH100	285	293	142	53	348	121	700	27	27
800	GB1950N/PR4.F2570.500	285	322.5	142.5	130	417	126	500	54	39
900	GB1950NLB/PR4.F3080.500-SH100	350	355	175	130	445	129	500	54	52
1000	GB6800N/PR4.F3080.500	370	407	170	182	470	159	500	81	62.5
1100	GB6800N/PR4.F3080.500	370	407	170	182	470	159	500	81	62.5
1200	GB6800N/PR4.F30100.600	370	407	170	182	480	159	600	117	62.5
1400	GBA200N/PR10.F30120.700	440	492	207.5	209	490.5	215	700	182.25	134.4
1600	GBIW82/R720.F35130.800	520	531	260	67	600.5	185	800	130	222

* n = Handradumdrehungen AUF/ZU

Material

GB232: Aluminium, Polyurethan beschichtet
 GB880-GB6800: Gusseisen, Polyurethan beschichtet

Installation als Endarmatur



Bei der Installation als Endarmatur, bitte Dokument Installation/Maintenance DESPONIA beachten.

Weitere Dokumentation

Pneumatische Antriebe, elektrische Antriebe, Zubehör gemäss separaten Datenblättern.
 Installations-, Wartungsanleitung, Flanschtabelle: Bitte beachten sie diese Anleitungen für die Installation und Wartung unserer Klappen.

Declaración de conformidad DEP 2014/68/UE
Declaration of Conformity PED 2014/68/EU

Fabricante <i>Manufacturer</i> 	InterApp-Valcom SA Calderon de la Barca 12-14 28860 Paracuellos de Jarama España	
---------------------------------------	---	--

Declaramos, que las válvulas abajo indicadas cumplen los requisitos de la directiva 2014/68/UE.
 We declare that the valves listed below comply with the requirements of the Pressure Equipment Directive 2014/68/EU.

Descripción: Válvula de mariposa <i>Description: Butterfly Valve</i>	- Desponia (Incluida S820) - Desponia <i>plus</i>	DN 25/32 – 1600 DN 25/32 – 600
---	--	-----------------------------------

Clasificación de la válvulas
Classification of the valves

Válvula de mariposa Desponia (incluida S820) DN 25/32- DN 1600
 Válvula de mariposa Desponia plus DN 25/32-600

Fluidos grupo 1 / Fluids group 1		Fluidos grupo 2 / Fluids group 2
Gases	Líquidos	Gases
DN25-32-150 PN2.5-20	DN150-200 PN16-PN20	DN50 PN20
DN200 PN2.5-16	DN250-300 PN10-PN20	DN65-100 PN16-PN20
DN250-350 PN2.5-10	DN350-800 PN6-PN20	DN125-150 PN10-PN20
	DN900-1200 PN2.5-PN20	DN200-250 PN6-PN20
	DN1400 PN2.5-PN16	DN300 PN6-PN16
	DN1600 PN2.5-PN10	DN350 PN6-PN10
		DN400-500 PN2.5-PN10
		DN600-800 PN2.5-PN6
		DN900-1600 PN2.5

Procedimiento de valoración de la conformidad <i>Conformity Assessment Procedure</i>	Módulo A1
Organismo Notificado para el control <i>Notified Body for the inspection</i>	TÜV Rheinland Ibérica, Inspection, Certification & Testing, S.A. N° 1027
Dirección <i>Address</i>	C/Garroba, 10-12 08820 El Prat de Llobregat.
Certificado-N° <i>Certificate number</i>	DEP.A1.000606
Normas empleadas <i>Technical Standards used</i>	EN 593; EN 1561; EN 1563; etc
Persona autorizada por el fabricante <i>Authorised Person for the Manufacturer</i>	Responsable de Calidad / <i>Quality Manager</i>

Alberto Nieto
(Name)

Firma:
(Signature)