

**HYDAC**

**FILTER SYSTEMS**

**FCM**

**FluidCleaner Mobil**

**Operating and Maintenance Instructions**

English (translation of original instructions)

Document no.: 3160267d



## Imprint

Publisher and responsible for the content:

HYDAC FILTER SYSTEMS GMBH

Postfach 1251

66273 Sulzbach / Saarland

Germany

Telephone: +49 (0)6897 509 01

Telefax: +49 (0)6897 509 846

E-Mail: [filtersystems@hydac.com](mailto:filtersystems@hydac.com)

Homepage: [www.hydac.com](http://www.hydac.com)

Court of Registration: Saarbrücken, HRB 17216

Executive director: Mathias Dieter,  
Dipl.Kfm. Wolfgang Haering

## Documentation Representative

Günter Harge

c/o HYDAC International GmbH, Industriegebiet, 66280 Sulzbach / Saar

Telephone: ++49 (0)6897 509 1511

Telefax: ++49 (0)6897 509 1394

E-Mail: [guenter.harge@hydac.com](mailto:guenter.harge@hydac.com)

## © HYDAC FILTER SYSTEMS GMBH - 2012

All rights reserved. No part of this work may be reproduced in any form (print, photocopy or by other means) or processed, duplicated or distributed using electronic systems without the written consent of the publisher.

These documents have been created and inspected with the greatest care. However, errors cannot be ruled out completely.

All details are subject to technical modifications. Technical specifications are subject to change without notice.

# Content

- Imprint ..... 2**
- Documentation Representative..... 2**
- Content..... 3**
- Preface ..... 5**
  - Customer Service ..... 6
  - Modifications to the Product ..... 6
  - Warranty ..... 6
  - Using the Documentation ..... 7
- Safety information and instructions ..... 8**
  - Obligations and liability ..... 8
  - Explanation of Symbols and Warnings, etc. .... 9
  - Proper/Designated Use ..... 9
  - Improper Use ..... 9
  - Safety Devices ..... 10
  - Informal Safety Precautions..... 10
  - Training and Instruction of Personnel ..... 11
  - Safety measures to be followed in normal operation ..... 12
  - Hazards Posed by Stored Residual Energy ..... 12
  - Maintenance, Servicing and Troubleshooting..... 12
  - Modifications to the FCM ..... 12
  - Fire Fighting ..... 12
- Storing the FCM..... 13**
- Transporting the FCM ..... 13**
  - By hand..... 13
  - Train / truck..... 13
  - Crane ..... 13
- Checking the scope of delivery ..... 14**
- FCM features..... 15**
  - Operating limitations ..... 15
- Dimensions ..... 16**
- Overview of FCM modules ..... 17**
  - Hydraulic schematic..... 18
- Preparing the FCM for operation ..... 19**
  - Inserting the filter element ..... 19
  - Notes on pipes and hoses ..... 20
  - Hanging / connecting the suction hose ..... 21

---

Hanging / connecting the pressure hose .....	21
Electrical connection of the FCM .....	22
Checking direction of rotation in jog mode.....	22
Pole changer (optional).....	23
Wiring diagram of the pole changer (optional) .....	23
<b>Controlling FCM via the clogging indicator (optional).....</b>	<b>24</b>
<b>Flow rate indicator (accessories) .....</b>	<b>24</b>
<b>Pump nozzle (accessories) .....</b>	<b>24</b>
<b>Switching on the FCM.....</b>	<b>25</b>
Selecting operating mode (optional) .....	25
<b>Performing Maintenance .....</b>	<b>26</b>
Maintenance intervals.....	26
<b>Changing the Filter Element.....</b>	<b>27</b>
Change the filter element .....	28
<b>Clean the suction strainer. ....</b>	<b>32</b>
<b>Disposing of the FCM .....</b>	<b>33</b>
<b>Errors and troubleshooting.....</b>	<b>33</b>
<b>Spare parts list .....</b>	<b>34</b>
<b>Technical Data .....</b>	<b>36</b>
<b>Model code.....</b>	<b>37</b>
Type code 'Filter concept' .....	38
<b>EC declaration of conformity .....</b>	<b>39</b>

## Preface

For you, as the owner of a product manufactured by us, we have produced this manual, comprising the most important instructions for its **operation** and **maintenance**.

It will acquaint you with the product and assist you in using it as intended in an optimal manner.

Keep it in the vicinity of the product so it is always available.

Note that the information on the unit's engineering contained in the documentation was that available at the time of publication. Consequently, there might be deviations in technical details, illustrations and dimensions.

If you discover errors while reading the documentation or have additional comments or suggestions, contact us at:

HYDAC Filter Systems GmbH  
Technische Dokumentation  
Postfach 12 51  
66273 Sulzbach / Saar  
Germany

We look forward to receiving your input.

**“Putting experience into practice”**

## Customer Service

If you have any questions, suggestions, or encounter any problems of a technical nature, please don't hesitate to contact us. When contacting us, please always include the model/type designation, serial no. and part-no. of the product:

Fax: ++49 (0) 6897 / 509 – 846

E-Mail: [filtersystems@hydac.com](mailto:filtersystems@hydac.com)

## Modifications to the Product

We would like to point out that changes to the product (e.g. purchasing options, etc.) may result in the information in the operating instructions no longer being completely accurate or sufficient.

After modification or repair work that affects the safety of the product has been carried out on components, the product may not be returned to operation until it has been checked and released by a HYDAC technician.

Please notify us immediately of any modifications made to the product whether by you or a third party.

## Warranty

We assume warranty in accordance with the General Terms of Sale and Delivery of HYDAC Filter Systems GmbH.

You'll find this under [www.hydac.com](http://www.hydac.com) -> General terms and conditions

## Using the Documentation



Note that the method described for locating specific information does not release you from your responsibility of carefully reading these instructions prior to starting the unit up for the first time and at regular intervals in the future.

### What do I want to know?

I determine which topic I am looking for.

### Where can I find the information I'm looking for?

The documentation has a table of contents at the beginning. There, I select the chapter I'm looking for and the corresponding page number.

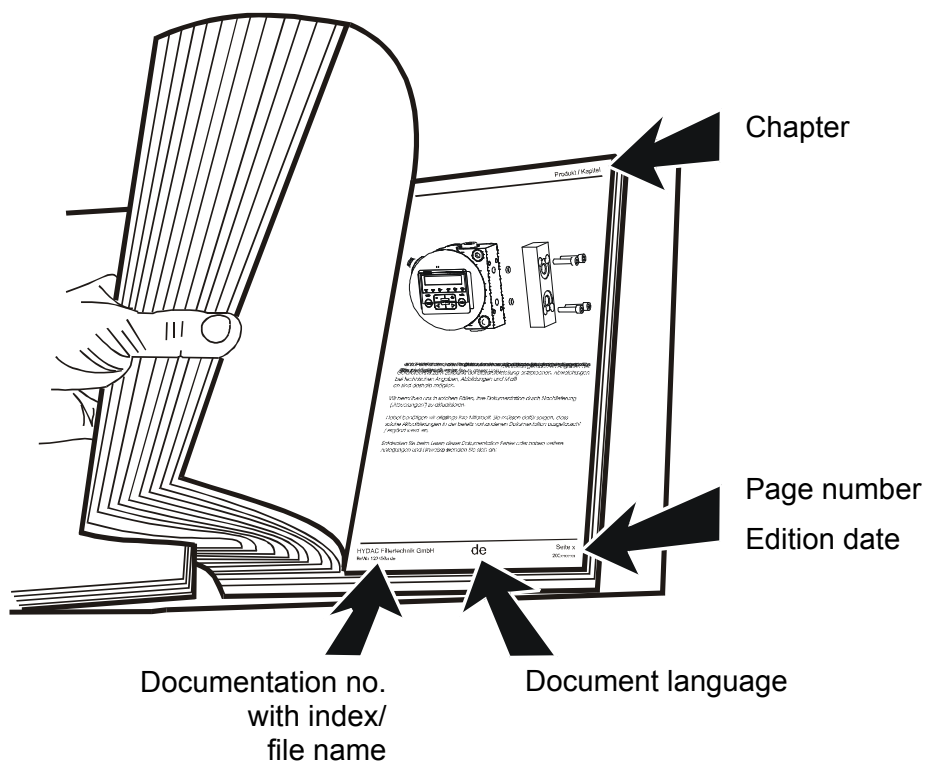

The documentation number with its index enables you to order another copy of the operating and maintenance instructions.  
The index is incremented every time the manual is revised or changed.

## Safety information and instructions

These operating instructions contain the key instructions for properly and safely operating your FCM.

### Obligations and liability

The basic prerequisite for the safe and proper handling and operation of the FCM is knowledge of the safety instructions and warnings.

These operating instructions in general, and the safety precautions in particular, are to be adhered to by all those who work with the FCM.

In addition, the accident prevention rules and regulation applicable at the location of use are to be observed.

The safety precautions listed herein are limited solely to using the FCM.

The FCM has been designed and constructed in accordance with the current state of the art and recognized safety regulations. Nevertheless, hazard may be posed to the life and limb of the individual using the product or to third parties. Nevertheless, hazard may be posed to the life and limb of the individual using the product or to third parties.

The FCM is to be used as follows:

- solely for its designated use
- only when in a safe, perfect condition

any faults or malfunctions which might impair safety are to be properly repaired or remedied immediately.

Our General Terms and Conditions apply. They are made available to the owner upon concluding purchase of the unit at the latest. Any and all warranty and liability claims for personal injuries and damage to property shall be excluded in the event they are attributable to one or more of the following causes:

- improper use of the FCM or use deviating from its designated use
- improper assembly, installation, commissioning, operation and maintenance of the FCM
- operating the FCM when the system equipment or systems are defective
- modifications to the FCM made by the user or purchaser
- Improper monitoring of unit components that are subject to wear and tear
- improperly performed repair work



## Explanation of Symbols and Warnings, etc.

The following designations and symbols are used in this manual to designate hazards, etc.:



DANGER denotes situations which can lead to death if safety precautions are not observed.



WARNING denotes situations which can lead to death if safety precautions are not observed.



CAUTION denotes situations which can lead to severe injuries if safety precautions are not observed.



NOTICE denotes situations which can lead to property damage if safety precautions are not observed.

## Proper/Designated Use

The FCM is a mobile filtration unit designed for circulation pumping with or without filtering fluids at the same time.

Any other use shall be deemed to be improper and not in keeping with the product's designated use.

The manufacturer will not assume any liability for any damage resulting from such use.

Proper or designated use of the product extends to the following:

- Maintaining adherence to all the instructions contained herein.
- Performing requisite inspection and maintenance work.

## Improper Use

Any use other than described above is prohibited.

Improper use may result in hazard to life and limb.

Example of improper use:

- Commissioning the unit without a dirt trap
- Using the unit with the wrong media

## Safety Devices

Prior to starting up the product, make sure that all the safety devices are properly fitted to the hydraulic system and are in proper working order.

## Informal Safety Precautions

Make sure to always keep the operating instructions in the vicinity of the product.

Apart from the operating instructions, any and all general and local regulations pertaining to accident prevention and environmental protection are to be made available and observance to be maintained to them.

All safety guidelines and hazard warnings on the machine must be maintained in legible condition and replaced as required.

The hoses and connection fittings are to be checked daily for leakage (visual check). The electrical components of the FCM are to also be regularly checked (visual check once a month). Any loose connections or damaged cables are to be replaced immediately.

## Training and Instruction of Personnel

The FCM may only be operated by properly trained and instructed personnel.

The areas of responsibility of your staff must be established in a clear-cut manner.

Staff undergoing training may not use the FCM unless supervised by an experienced staff member.

Activity	Individuals	Individuals undergoing training	Individuals with technical training/ engineering background	Electricians	Supervisor with the appropriate authority
Packing / transportation		X	X		X
Commissioning			X	X	X
Operation		X	X	X	X
Troubleshooting/ locating the source of malfunction			X	X	X
Troubleshooting, mechanical problem			X		X
Remedying of electrical faults				X	X
Maintenance		X	X	X	X
Repair work					X
Decommissioning / storage		X	X	X	X

## **Safety measures to be followed in normal operation**

Do not operate the FCM unless all the safety devices function properly.

Check the product for visible damage and properly functioning safety equipment at least once a day.

## **Hazards Posed by Stored Residual Energy**

Note that the unit may pose a hazard as the result of residual stored mechanical and electrical energy. Take the proper precautions when instructing personnel on the use of the unit. Detailed information is provided in the respective chapters of this manual.

## **Maintenance, Servicing and Troubleshooting**

The specified adjustment, maintenance, and inspection work is to be conducted in a timely fashion.

Secure all operating media against accidental start up.

The FCM is to be disconnected from the power supply and protected against being inadvertently switched back on when performing any maintenance, servicing, inspection or repair work.

Check that released threaded joints were refit tightly.

Always check the safety devices to see that they function properly after performing maintenance work.

## **Modifications to the FCM**

Do not make any modifications (design modifications, extensions) to the FCM without the prior consent of the manufacturer.

Immediately replace any unit components which are not in perfect condition.

Use only original spare parts (OEM). When using non-OEM components, it cannot be ensured that they have been designed and manufactured so as to comply with loading and safety requirements.

## **Fire Fighting**

When fighting a fire make sure to disconnect the unit from the power supply, otherwise an electrical fire cannot be effectively dealt with.

## Storing the FCM

Drain the unit completely before putting it into extended storage.

Pull the power plug and wind up the power cord.

Attach the suction and pressure hoses to the unit and secure them.

## Transporting the FCM

### By hand

The unit may be grasped only on the handles provided and shifted by hand.

### Train / truck

When transported by truck / train, the unit must be lashed securely to a pallet.

### Crane

For transport by crane, the unit has an eyelet provided.

Only use suitable lifting accessories.

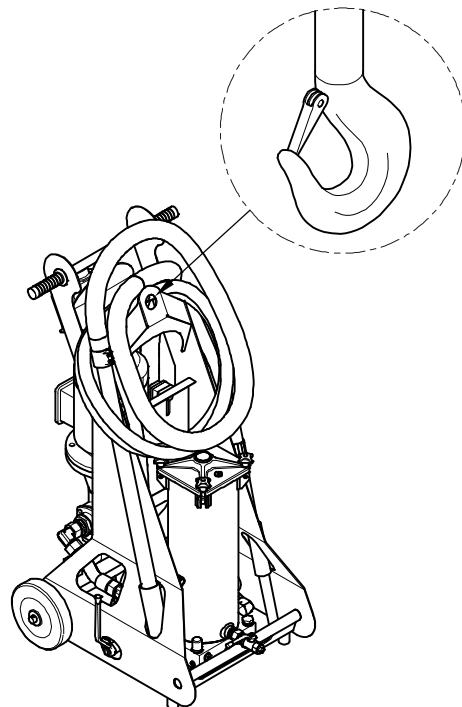

## Checking the scope of delivery

Before commissioning the unit, check it for completeness and any possible damage.

Report any damages in transit to the transport company or the responsible agent immediately. Do not put the unit into operation.

The following items are supplied:

Qty.	Name
1	FluidCleaner Mobil
1	Filter element
1	Suction hose
1	Pressure hose
1	Operation and Maintenance Instructions (this document)
1	Certificate



## FCM features

The Fluid Cleaner Mobile unit is a mobile filtration-pumping unit designed for oil servicing which, depending on the version (with or without the change-over feature), can be used for pumping or pumping and filtering fluids.

## Operating limitations

### NOTICE

#### Impermissible operating media

The unit will be damaged

- ▶ The unit is only to be used with mineral oils or mineral oil-based raffinates.

## Dimensions

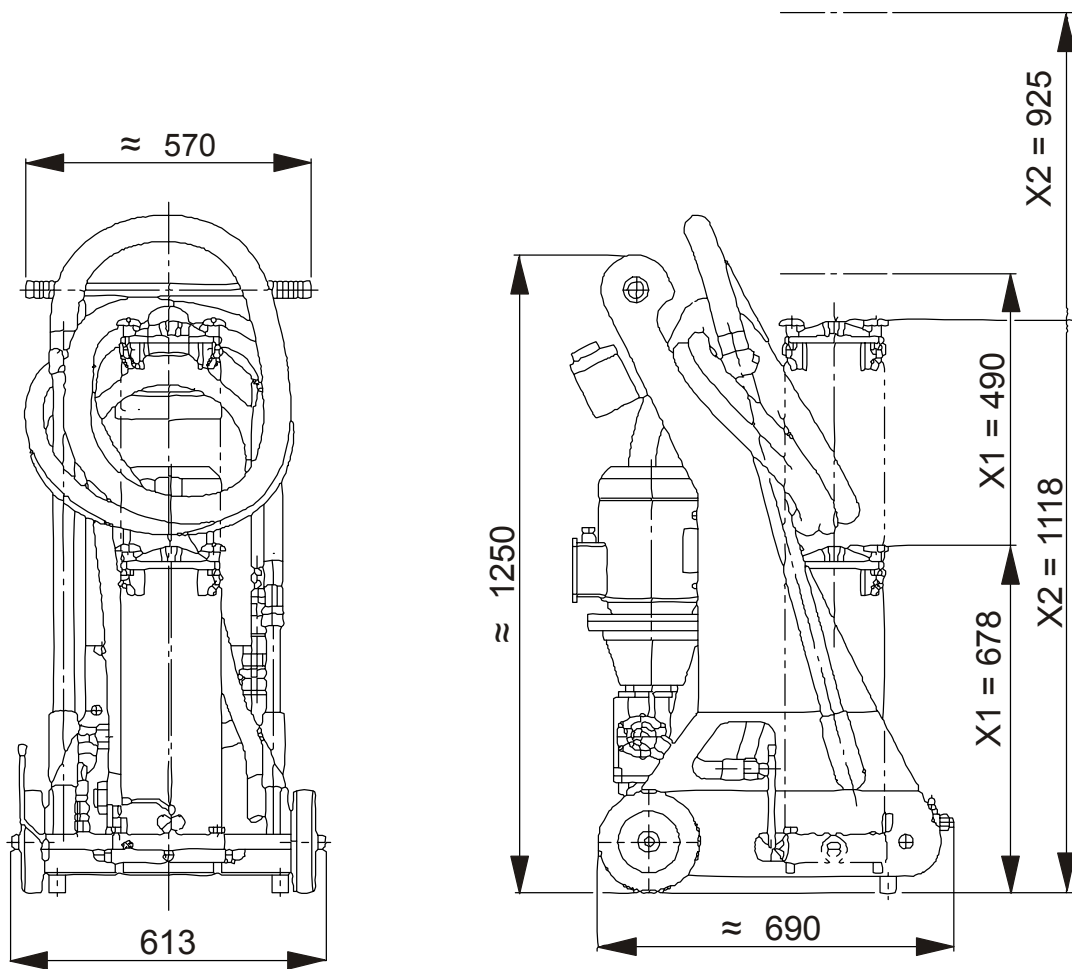

X1 = 1300 Filter size

X2 = 2600 Filter size



## Overview of FCM modules

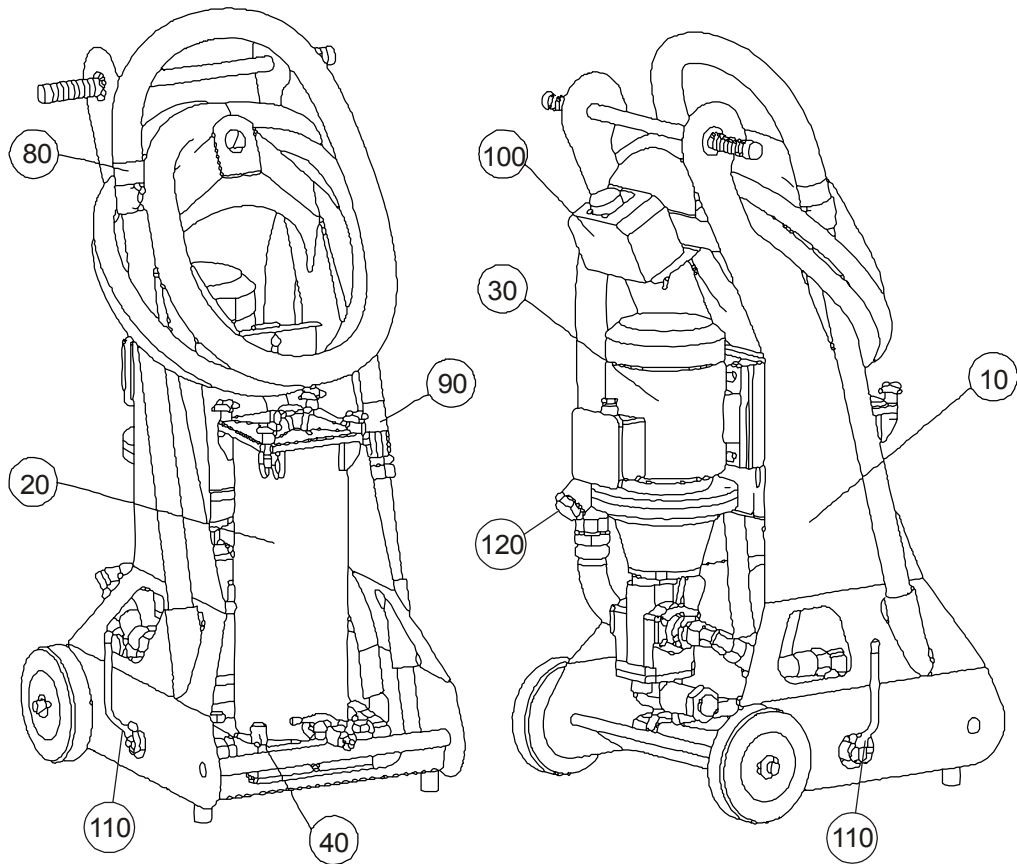

Item	Name
10	Chassis
20	Fluid filter (1300/2600)
30	Motor-pump assembly
40	Contamination indication
80	Suction hose with lance
90	Pressure hose with lance
100	with on-off switch and overload protective switch
110	Operating change-over (Option)
120	Suction strainer

### Hydraulic schematic

FCM without change-over (**FCM xxx L x xxx x / FCM xxx K x xxx**)

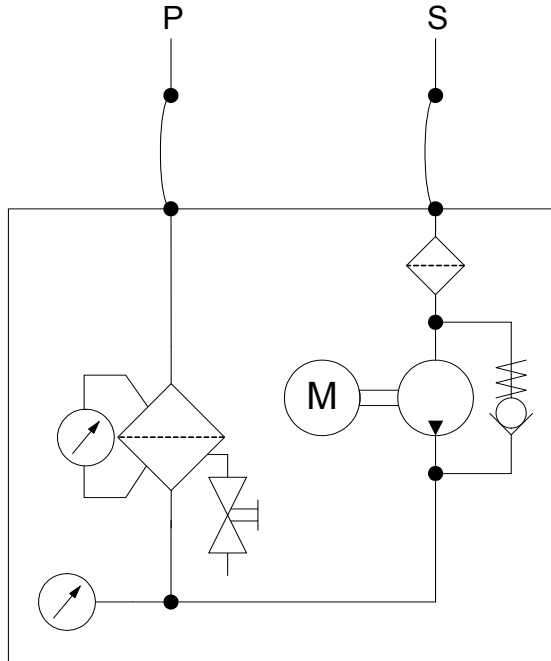

FCM with change-over (**FCM xxx F x xxx x / FCM xxx G x xxx**)

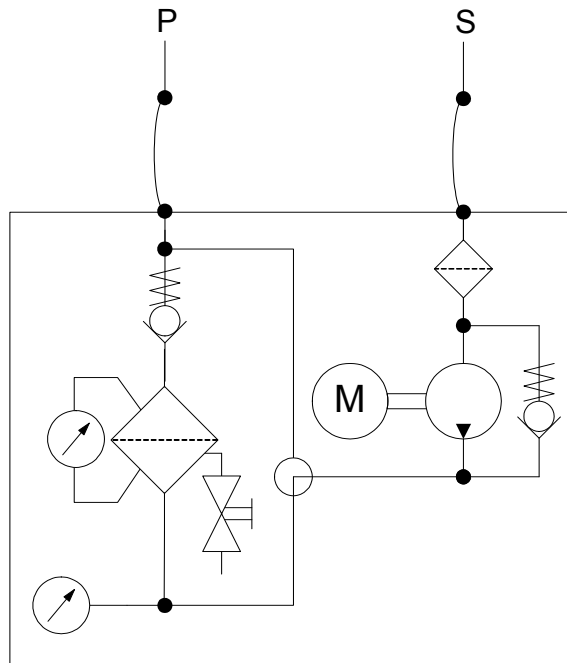

## Preparing the FCM for operation

### Inserting the filter element

The unit is delivered with no filter element installed. Make sure that there is a filter element in the fluid filter before commissioning.

You can find details about changing the filter element on page 27.

## Notes on pipes and hoses

Make sure that no vibrations or stress/loading from other machinery and equipment are carried over to filter housing. If necessary, use expansion joints.

The pressure loss in a hydraulic line depends upon:

- Flow rate
- Kinematic viscosity
- Pipe dimensions
- fluid density

The pressure loss can be estimated for hydraulic oils as follows:

<b><math>\Delta p \approx 6,8 * L / d^4 * Q * V * D</math></b>	
$\Delta p$	= Pressure differential in [bar]
$L$	= Line length [m]
$d$	= Internal line diameter [mm]
$Q$	= Flow rate [l/min]
$V$	= Kinematic viscosity [mm <sup>2</sup> /s]
$D$	= Density [kg/dm <sup>3</sup> ] Mineral oil-based hydraulic fluid has a density of $\approx 0.9$ kg/dm <sup>3</sup> .

This applies to straight pipelines and hydraulic oils. Additional threaded connections and pipe bends increase the pressure differential.

Keep the height difference between the pump and the oil level in the tank as low as possible.

Constrictions in the connections and lines should be avoided. This could compromise suction output and cause cavitation .

Take note that the nominal size of the connected hoses/piping must be at least as large as the inlet port sizes.

Make sure that no vibrations or stress/loading from other machinery and equipment are carried over to filter unit. Use hoses or expansion joints if necessary.

## Hanging / connecting the suction hose

### NOTICE

#### Contamination too high

The unit will be damaged

- ▶ Do not prime directly at the bottom of the tank
- ▶ Do not prime in the sump
- ▶ Never prime without a built-in suction screen



The greatest contamination is found on the bottom of the tank. All impurities and other particles are deposited on the bottom of the tank.

Pull the suction hose (transparent hose) with lance out of the seat in the floor plate.

Put the suction hose with lance, without tension and or twist, into the appropriate container and secure it.

## Hanging / connecting the pressure hose

Pull out the pressure hose (black hose) with lance from the seat in the floor plate and insert it in the appropriate receptacle.

Put the pressure hose with lance, without tension and or twist, into the appropriate container and secure it.



To prevent air from entering the medium, make sure that the pressure hose with lance is always below the oil level in operation.

## Electrical connection of the FCM

Plug the power plug into a suitable power outlet.

Check that the voltage and frequency are correct.

The unit has a motor protection switch in the on / off switch. If the nominal current is exceeded, the motor protection switch trips.

## Checking direction of rotation in jog mode

Start the motor by switching it on for a short time (jog mode). The arrow on the fan cover shows the correct direction of rotation.

If the rotation is in the opposite direction, it must be reversed using the phase inverter in the connection plug.

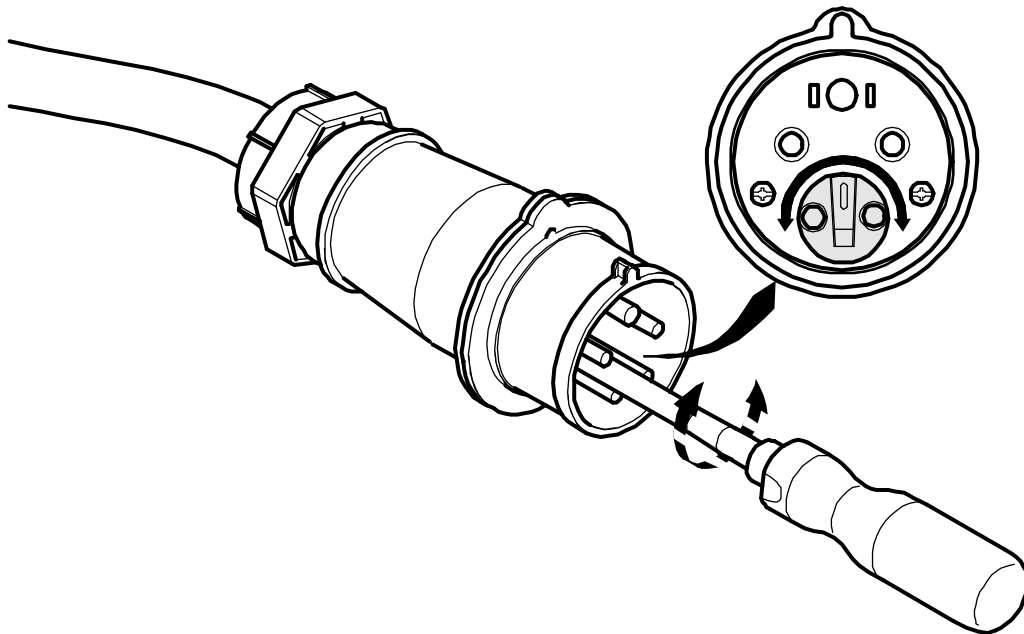

### Pole changer (optional)

With the optional pole changer you can operate the motor at two different rotation speeds and thus two different flow rates. To do this, observe the position of the selector switch.

Position of switch:



Position of switch:



- 0 = OFF
- 1 = Motor speed: 720 rpm, ~ 70 l/min
- 2 = Motor speed: 1450 rpm, ~ 140 l/min

### Wiring diagram of the pole changer (optional)

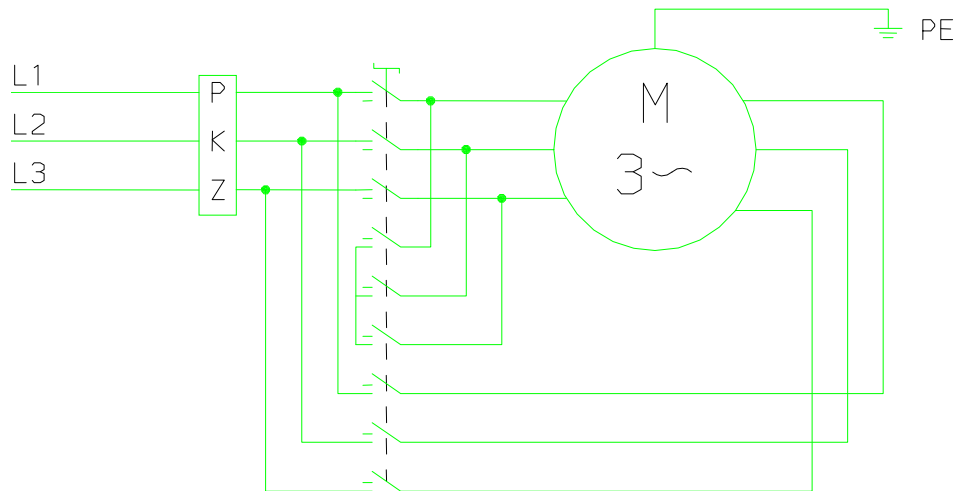

## Controlling FCM via the clogging indicator (optional)

The special version "Switching off the motor via the clogging indicator" allows monitoring-free operation of the filter contamination.

If the differential pressure of 2 bar above the filter element is exceeded, the clogging indicator switched the motor-pump assembly off and the "Filter clogged" lamp lights up.

### NOTICE

#### Neutral wire missing

Unit does not switch off

- ▶ Check if the power outlet has a neutral conductor, or have this checked before commissioning.

## Flow rate indicator (accessories)

During operation with the flow rate indicator, observe the corresponding operating instructions.

## Pump nozzle (accessories)

During operation with a pump nozzle, observe the corresponding operating instructions.



## Switching on the FCM

The on / off switch of the unit has a motor protection switch. This permanently monitors the nominal current during operation and switches the unit off in case of overload.

After switching on the motor, monitor the suction action via the transparent suction hose.

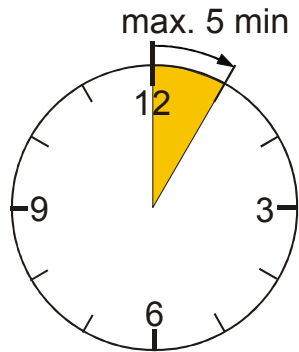

If the unit is not feeding medium after a maximum of 5 minutes of operation, the pump must be pre-filled.

Switch the motor off and fill the unit using the suction hose.

It is not normally necessary to vent the filter housing because of the special element locating spigot.

During operation, always monitor:

- the filtration unit so that possible leaks can be recognized immediately.
- the clogging indicator so that the filter element can be changed in a timely manner.

When the visual clogging indicator is red, change the filter element immediately.

if the maximum operating pressure is exceeded, the differential pressure relief valve in the pump will direct the medium back to the suction side. The opening of the differential pressure relief valve will make a loud noise.

## Selecting operating mode (optional)

If the unit is equipped with a switchover (type code: **FCM xxx F x xxx / FCM xxx G x xxx**), the following operating modes can be selected.

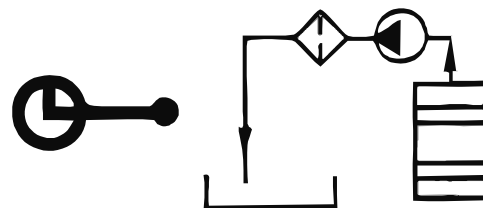

Circulation pumping with filtration

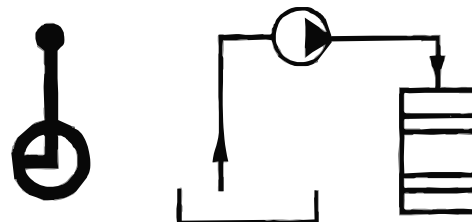

Circulation pumping without filtration



## Performing Maintenance

	<p><b>! WARNING</b></p> <p><b>Operating pressure</b></p> <p>Danger of bodily injury</p> <ul style="list-style-type: none"> <li>▶ The hydraulic system must be depressurized before performing any work on the hydraulic system</li> </ul>
	<p><b>! DANGER</b></p> <p><b>Electric shock</b></p> <p><b>Danger of fatal injury</b></p> <ul style="list-style-type: none"> <li>▶ Any work involving the electrical equipment may only be done by a properly trained, certified electrician.</li> <li>▶ Pull power plug before performing any work.</li> </ul>

## Maintenance intervals

	Daily	Monthly	Annually
Visual inspection for: leakage and damage	X		
Clean the suction strainer.		X	
Changing the Filter Element			X

## Changing the Filter Element

### NOTICE

#### Unsuitable filter element

Fluid is not filtered

- Use only filter elements with the type code suffix **-KB**  
(for example: 1300 R 003 BN4HC **-KB**)

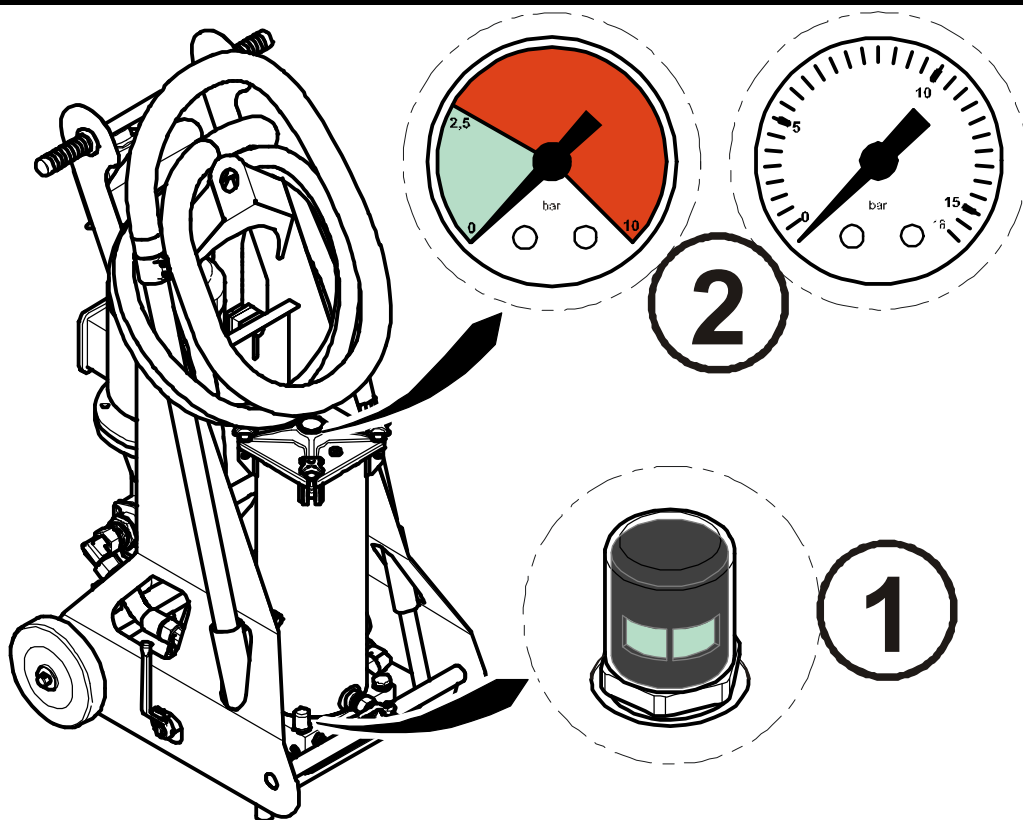

The standard model has an optical (green/red) differential pressure indicator (1) and an optical back-pressure indicator in the cover of the filter (2).

The type of differential pressure indicator (1) / back-pressure indicator (2) varies according to model code.

**Change the filter element**

1. Switch the unit off.  
Pull power plug.
2. Depressurize the filter housing.  
Remove the air bleed plug (1) in the filter cover for this purpose.  
  
The residual oil is drained through the drain ball valve (2) into a suitable container.

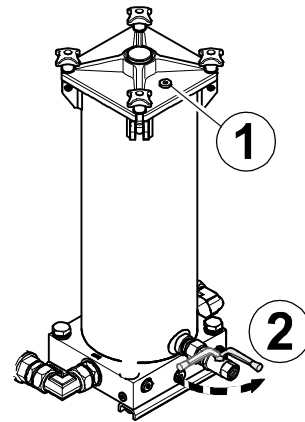

3. Loosen the four screws on the cover counterclockwise.

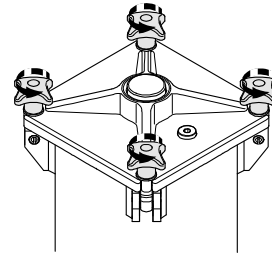

4. Fold the screws down and press them against the filter housing.  
This pushes the cover of the filter housing up.

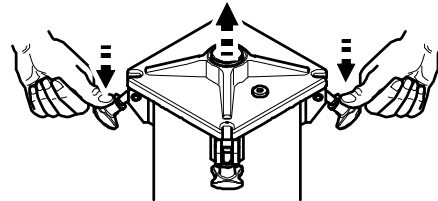

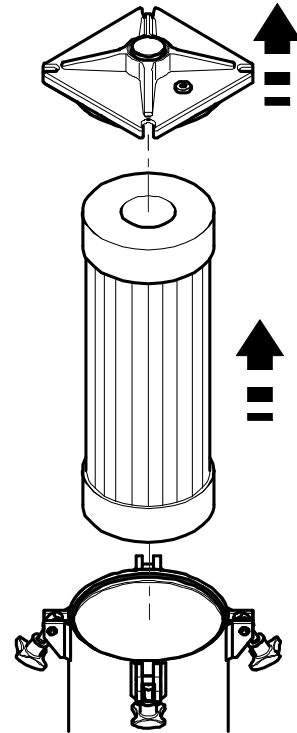

5. Take the cover off and remove the filter element.

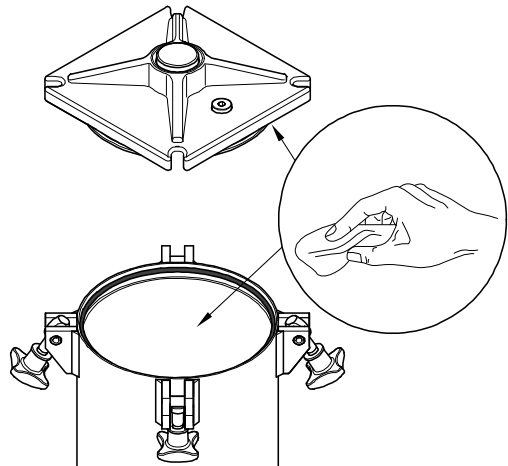

6. Clean:

- the inside of the filter bowl of coarse dirt
- the sealing surfaces on the filter head and on the cover.



6.  For easier installation of the filter element, wet the O-ring on the filter element with the operating medium.

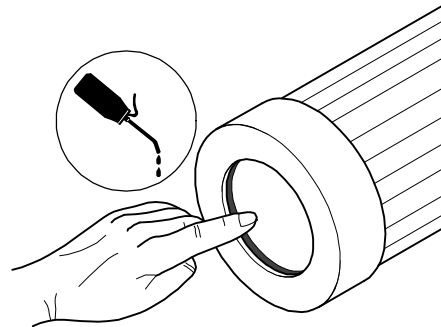

7. Press the new filter element down into the filter mount by turning it slightly.



Do not use striking tools for this.

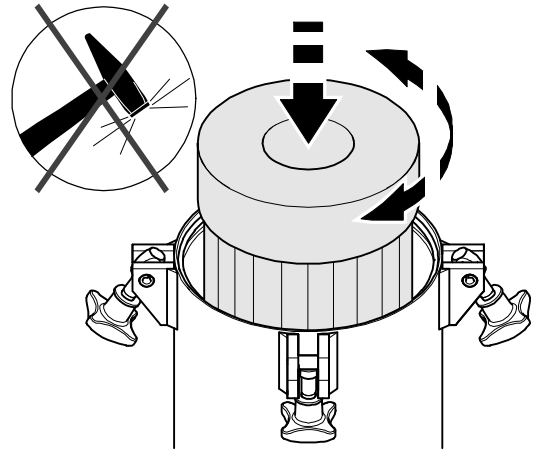

8. Check the O-ring on the cover for damage and replace it if necessary.

Lightly wet the O-ring on the cover with medium.

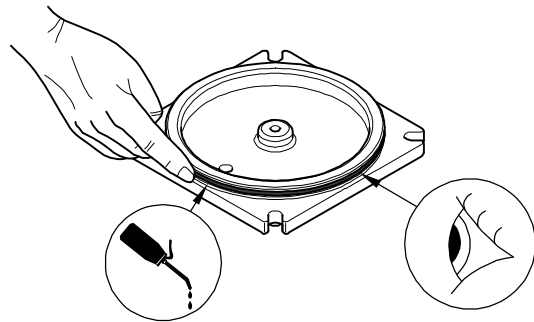

9. Put the cover on.



Observe correct placement of the O-ring on the cover while doing so. It must not be damaged.

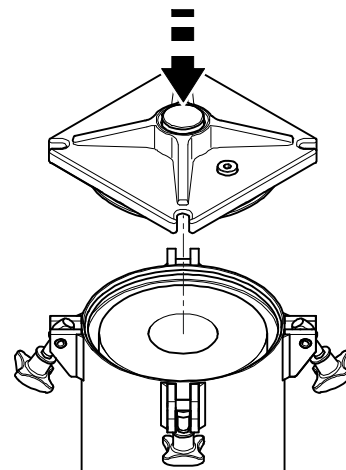

10. Fold the four screws up and turn them clockwise evenly crosswise.

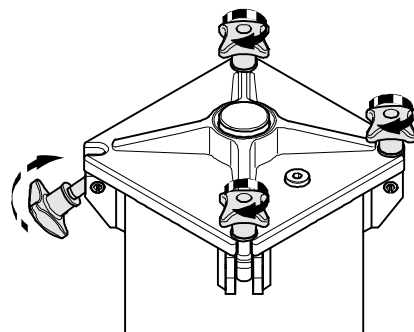

11. Close the drain valve.

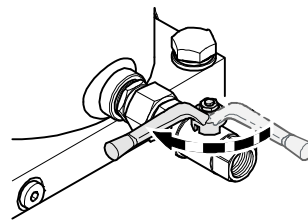

12. Plug in the power plug.  
Switch the unit on.
13. Check the unit for any leaks.

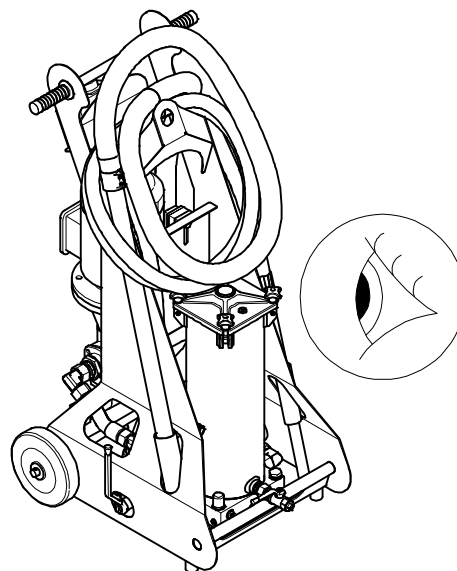

14. The unit is ready for operation.

## Clean the suction strainer.

### NOTICE

#### Operation without a suction strainer

Pump is disrupted

- ▶ The FCU may not be operated without the suction strainer.
- ▶ Clean the suction strainer regularly.

To protect the pump from coarse contamination particles and other foreign bodies, a dirt trap with a strainer insert is fitted at the pump inlet.

This strainer insert must be cleaned at regular intervals, e.g. by flushing it with solvent or blow-flushing it with compressed air.

1. Unscrew the screw plug (1) counterclockwise with an open-jaw wrench (wrench width 50 mm).
2. Remove strainer insert (2) and clean it.
3. Check strainer insert (2) and the seal ring on the screw plug for damage and replace if necessary.
4. Insert strainer insert (2).
5. Screw in the screw plug clockwise and tighten it with the open-jaw wrench (wrench width 50 mm).
6. After start-up, check the suction strainer fittings for leaks.

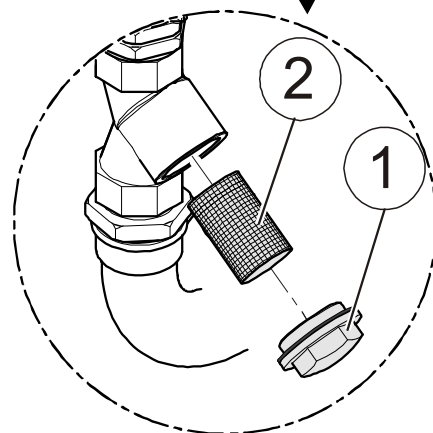
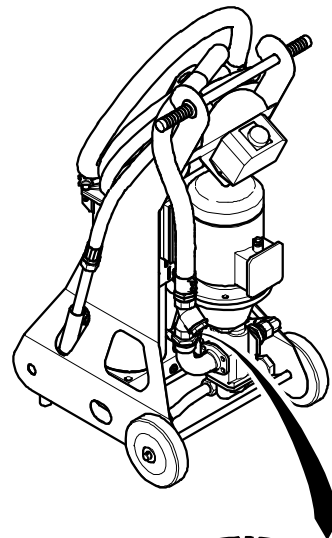

The entry of air causes a loud noise and can damage the pump.



## Disposing of the FCM

After dismantling the emptied unit and separating the various materials, dispose of the unit in an environmentally friendly manner.

## Errors and troubleshooting

Error	Cause(s)	Remedy
Differential pressure > 2 bar	Pronounced contamination of the medium	Replace filter element
	Contamination retention capacity of the filter element reached.	Replace filter element
	Viscosity too high	Warm medium up
No flow	The pump is conveying in the wrong direction.	Check the rotational direction of the motor and, if necessary, reverse the phases.
	suction hose not deep enough in the container	Sufficiently immerse the suction hose in the medium
No function	Not connected to power supply.	Check the electrical connections, such as the plug, cables and outlet
Loud operating noise in the pump	Response of the differential pressure relief valve	Operating pressure over maximum
	Suction strainer clogged	Clean the suction screen

## Spare parts list

Designation			Part no.
1300 filter element 3 µm	2B03 - 1300 R 003 BN4HC-/KB	NBR	1263059
1300 filter element 3 µm	2B03 - 1300 R 003 BN4HC-/-V-KB	FPM	1263760
1300 filter element 5 µm	2B05 - 1300 R 005 BN4HC-/KB	NBR	1263060
1300 filter element 5 µm	2B05 - 1300 R 005 BN4HC-/-V-KB	FPM	1263761
1300 filter element 10 µm	2B10 - 1300 R 010 BN4HC-/KB	NBR	1263061
1300 filter element 10 µm	2B10 - 1300 R 010 BN4HC-/-V-KB	FPM	1263762
1300 filter element 20 µm	2B20 - 1300 R 020 BN4HC-/KB	NBR	1263062
1300 filter element 20 µm	2B20 - 1300 R 020 BN4HC-/-V-KB	FPM	1263763
1300 filter element 40 µm	2A40 - 1300 R 040 AM-/KB	NBR	1267699
1300 filter element 10 µm	2BA40 - 1300 R 010 BN4AM-/KB	NBR	1270010
1300 filter element 3 µm	2BA03 - 1300 R 003 BN4AM-/KB	NBR	1267991
2600 filter element 3 µm	3B03 - 2600 R 003 BN4HC-/KB	NBR	1263071
2600 filter element 3 µm	3B03 - 2600 R 003 BN4HC-/-V-KB	FPM	1263784
2600 filter element 5 µm	3B05 - 2600 R 005 BN4HC-/KB	NBR	1263072
2600 filter element 5 µm	3B05 - 2600 R 005 BN4HC-/-V-KB	FPM	1263785
2600 filter element 10 µm	3B10 - 2600 R 010 BN4HC-/KB	NBR	1263073
2600 filter element 10 µm	3B10 - 2600 R 010 BN4HC-/-V-KB	FPM	1263786
2600 filter element 20 µm	3B20 - 2600 R 020 BN4HC-/KB	NBR	1263074
2600 filter element 20 µm	3B20 - 2600 R 020 BN4HC-/-V-KB	FPM	1263787
2600 filter element 40 µm	3A40 - 2600 R 040 AM-/KB	NBR	306899
2600 filter element 3 µm	3BA03 - 2600 R 003 BN4AM-/KB	NBR	1268232
Pressure gauge	NG40		36198
Differential pressure gauge	VM 2 B.1		303191
Pressure hose	Length = 4 m with lance	NBR	91205
Pressure hose	Length = 5 m with lance	NBR	349357
Pressure hose	Length = 10 m with lance	NBR	349109
Pressure hose	Length = 18 m with lance	NBR	349078
Pressure hose	Length = 4 m without coupling		632063
Pressure hose	Length = 5 m without coupling		632165

Designation			Part no.
Suction hose	Length = 2.5 m with lance	PVC/ NBR	92172
Suction hose	Length = 5 m with lance	PVC/ NBR	349503
Suction hose	Length = 5 m with coupling	PVC/ NBR	349666
Suction hose	Length = 3 m with coupling	PVC/ NBR	349665
Electric motor for FCM-060-L/F	400 V-50 Hz-3 Ph		6014525
Electric motor for FCM-060-L/F	230V-50Hz-1Ph		636131
Electric motor for FCM-100-L/F	400 V-50 Hz-3 Ph		609085
Vane pump	FCM-060-L/F, 2/2.1/P/90/40/RV6		721009
Vane pump	FCM-100-L/F, 3/3.0/P/100/ 70/RV6		721231
Repair kit for vane pump	(M)FZP-2/2.1 NBR		382438
Repair kit for vane pump	(M)FZP-3/3.0 NBR		383765
Gear pump assembly	KF40RF1 for FCM 060 /400V		6000940
Gear pump assembly	KF63RF1 for FCM 100 /400V		6000941
Suction strainer, assembly			616851
Suction strainer insert	250 µm		617902
Seal ring for the suction strainer			6039370

\*) on request

## Technical Data

	FCM 060	FCM 100
Maximum flow rate	60 l/min	100 l/min
pump	Vane pump	Gear pump
Operating pressure, maximum	6 bar	10 bar
Viscosity range Vane pump	15 ... 400 mm <sup>2</sup> /s	15 ... 400 mm <sup>2</sup> /s
Viscosity range Gear type pump	15 ... 1000 mm <sup>2</sup> /s	15 ... 1000 mm <sup>2</sup> /s
Hydraulic fluid temperature	-10 ... 80°C	-10 ... 80°C
Ambient temperature	-10 ... 40°C	-10 ... 40°C
Sealing material	NBR / FKM	NBR / FKM
Power consumption Vane pump	1,5 kW	2,2 kW
Power consumption Gear type pump	2,2 kW	3,0 kW
IP class	IP 55	IP 55
Length of electrical connection cable	6 m	6 m
Hydraulic connectors	IN 1 ½" OUT M 36x2	IN 1 ½" OUT M 36x2
Suction hose, length	3 m	3 m
Pressure hose, length	4 m	4 m
Weight	~ 135 kg	~ 145 kg

## Model code

	FCM	-	100	-	L	-	N	-	3B03	-	B	/-	S5D5-V
<b>Product</b>													
FCM	= FluidCleaner Mobil												
<b>Delivery action</b>													
060	= 60 l/min												
100	= 100 l/min												
<b>Version</b>													
L	= Vane pump without change-over												
F	= Vane pump with change-over												
K	= Gear pump without change-over												
G	= Gear pump with change-over												
<b>Power supply voltage</b>													
M*	= 230 V / 50 Hz (1 Ph + PE)												
N	= 400 V / 50 Hz (3 Ph + PE)												
S	= 500 V / 50 Hz (3 Ph + PE)												
X	= other voltage												
<b>Filter concept</b> (for details see table on page 38)													
2	= Filter size 1300												
3	= Filter size 2600												
<b>Contamination indication</b>													
B	= optical differential pressure indication												
C	= Special version – electric differential pressure sensor (VM 2 C.0) with automatic motor switch-off in case of filter contamination												
<b>Supplementary details</b>													
-	= Series												
S5	= Suction hose with lance, l= 5 m												
D5	= Pressure hose with lance, l= 5 m												
V	= Seal material FKM (FPM, Viton®)												
SK	= Suction hose with threaded connection												
DK	= Pressure hose with threaded connection												
*) Only for version FCM 060 (1.5 kW)													

## Type code 'Filter concept'

Filter size	Filtration rating	Model code	Element type
2	3 µm	<b>2B03</b>	1300 R 003 BN4HC
2	5 µm	<b>2B05</b>	1300 R 005 BN4HC
2	10 µm	<b>2B10</b>	1300 R 010 BN4HC
2	20 µm	<b>2B20</b>	1300 R 020 BN4HC
2	40 µm	<b>2A40</b>	1300 R 040 AM
2	10 µm	<b>2A10</b>	1300 R 010 BN4AM
2	3 µm	<b>2A03</b>	1300 R 003 BN4AM
3	3 µm	<b>3B03</b>	2600 R 003 BN4HC
3	5 µm	<b>3B05</b>	2600 R 005 BN4HC
3	10 µm	<b>3B10</b>	2600 R 010 BN4HC
3	20 µm	<b>3B20</b>	2600 R 020 BN4HC
3	40 µm	<b>3A40</b>	2600 R 040 AM
3	3 µm	<b>3A03</b>	2600 R 003 BN4AM

# EC declaration of conformity



## FILTER SYSTEMS

### HYDAC FILTER SYSTEMS GMBH

Postfach 12 51  
66273 Sulzbach / Saar  
Germany

Industriegebiet  
66280 Sulzbach / Saar  
Germany

Telefon: ++49 (0) 6897 509 01  
Internet: www.hydac.com



## EC declaration of conformity

We hereby declare that the following designated product, on the basis of its design and construction, and in the version which we have brought to market, corresponds to the fundamental safety and health requirements contained in the standards listed below.

Any modification of this product that is not coordinated with us in writing will cause this declaration to lose its validity.

Name	Filtration unit
Typ	FCM Series
Part no.	
Serial no.	
EU-Machinery Directive	2006/42/EC
EU Electrical Equipment Regulations	2006/95/EC
EU-Directive on Electromagnetic Compatibility	2004/108/EC
Safety of machinery and devices	EN 12100-1/2

2009-12-22	Dr. Andreas Schunk	
Date	Name	(CE official)

Executive director:  
Mathias Dieter, Dipl.Kfm. Wolfgang Haering  
Registered seat of company: 66280 Sulzbach / Saar - Germany  
Registry Court: Saarbrücken, HRB 17216  
Value added tax identification number: DE 815001609  
Tax number : 040/110/50773



# FILTER SYSTEMS

HYDAC FILTER SYSTEMS GMBH

Industriegebiet

66280 Sulzbach/Saar

Germany

Postfach 1251

66273 Sulzbach/Saar

Germany

Phone: +49 (0) 6897 509 01

Fax: +49 (0) 6897 509 846

Fax: +49 (0) 6897 509 577

Central

Technical Department

(Sales Department)

Internet: [www.hydac.com](http://www.hydac.com)

Email: [filtersystems@hydac.com](mailto:filtersystems@hydac.com)